

# Resistance Thermometers

## Model TR217, with Spring-Loaded Probe Tip

WIKA Data Sheet TE 60.22



### Applications

Temperature measurement at bearings of:

- Pumps
- Gears
- Motors

### Special Features

- Application ranges from -50 °C to +450 °C
- Compact design
- Probe tip spring-loaded
- Intrinsically safe versions (ATEX)



**Resistance Thermometer with Spring-Loaded Probe Tip,  
Model TR217**

### Description

The resistance thermometer TR217 is ideally suited for the measurement of the surface temperature at the bearings of pumps, gears or motors under dry ambient conditions at the probe tip. The spring-loaded, plane probe tip guarantees a constant contact pressure of the thermometer on the outer surface of the bearing shell. The optimum insertion depth can be set by means of a compression fitting.

Analogue or digital transmitters built into the connection head are capable of making various output signals such as

4 ... 20 mA, HART protocol, Profibus PA or FOUNDATION Fieldbus available.

Intrinsically safe designs are available for applications in hazardous areas.

The models of the TR217 series are provided with a type examination certificate for "intrinsically safe" type of protection according to directive 94/9/EC (ATEX). Manufacturer's Declarations in accordance with EN 50 020 are also available.

# Sensor

The sensor is located in the tip of the measuring insert.

## Sensor method of connection

- 2 wire
- 3 wire
- 4 wire

With 2 wire connection the lead resistance of the measuring insert compounds the error.

## Sensor limiting error

- class B to DIN EN 60 751
- class A to DIN EN 60 751
- 1/3 DIN B at 0 °C

It makes no sense to combine 2 wire connection with class A or 2 wire connection with 1/3 DIN B, because the lead resistance of the measuring insert overrides the higher sensor accuracy.

## Basic values and limiting errors

Basic values and limiting errors for the platinum measurement resistances are laid down in DIN EN 60 751. The nominal value of Pt 100 sensors is 100 Ω at 0 °C. The temperature coefficient α can be stated simply to be between 0 °C and 100 °C with:

$$\alpha = 3.85 \cdot 10^{-3} \text{ } ^\circ\text{C}^{-1}$$

The relationship between the temperature and the electrical resistance is characterised by polynomials which are defined in DIN EN 60 751. Furthermore, this standard lays down the basic values in °C stages.

Class	Limiting error in °C
A	$0.15 + 0.002 \cdot  t $ <sup>1)</sup>
B	$0.3 + 0.005 \cdot  t $

1) |t| is the value of the temperature in °C without consideration of the sign

Temperature (ITS 90) °C	Basic value Ω	Limiting error DIN EN 60 751			
		Class A		Class B	
		°C	Ω	°C	Ω
-50	80.31	± 0.25	± 0.10	± 0.55	± 0.22
0	100	± 0.15	± 0.06	± 0.3	± 0.12
50	119.40	± 0.25	± 0.10	± 0.55	± 0.21
100	138.51	± 0.35	± 0.13	± 0.8	± 0.30
200	175.86	± 0.55	± 0.20	± 1.3	± 0.48
300	212.05	± 0.75	± 0.27	± 1.8	± 0.64
400	247.09	± 0.95	± 0.33	± 2.3	± 0.79

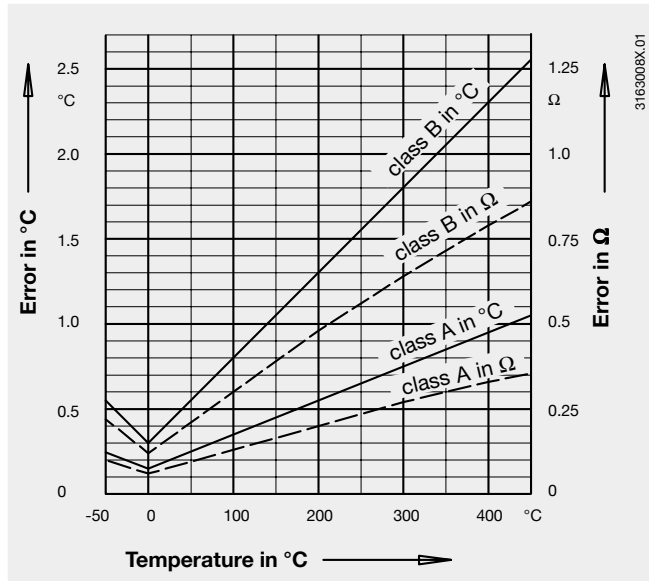

## Note:

These thermometers are primarily used for the measurement of surface temperatures. The accuracies specified refer to the Pt100 sensor. Unfavourable mounting and operating conditions can result in incorrect measurement values.

## TR217 components

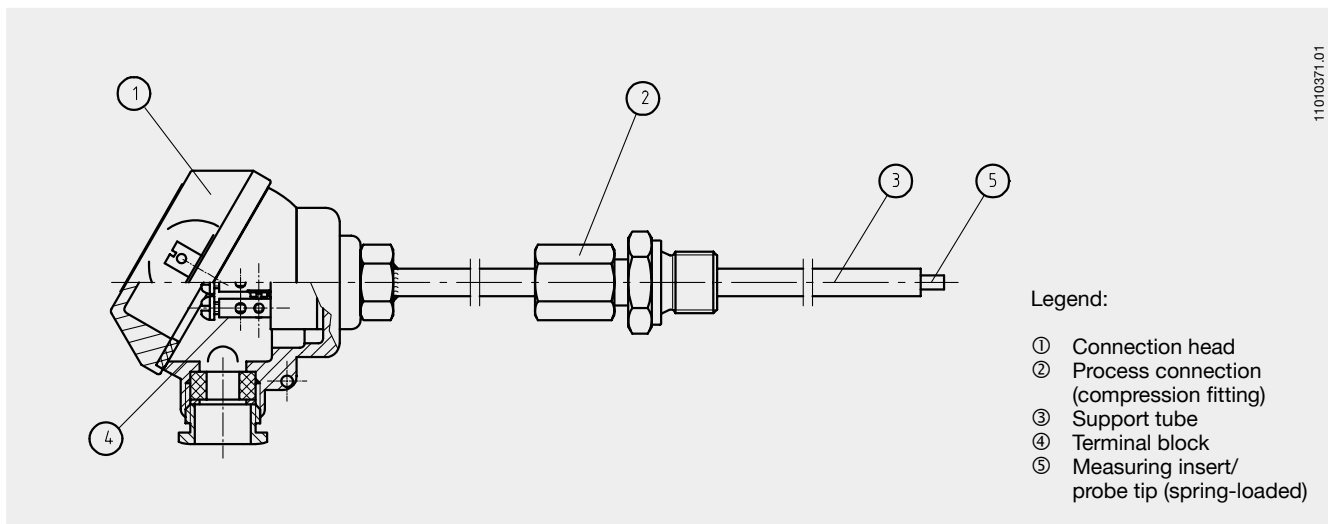

### Legend:

- ① Connection head
- ② Process connection (compression fitting)
- ③ Support tube
- ④ Terminal block
- ⑤ Measuring insert/probe tip (spring-loaded)

## Connection head / connector plugs

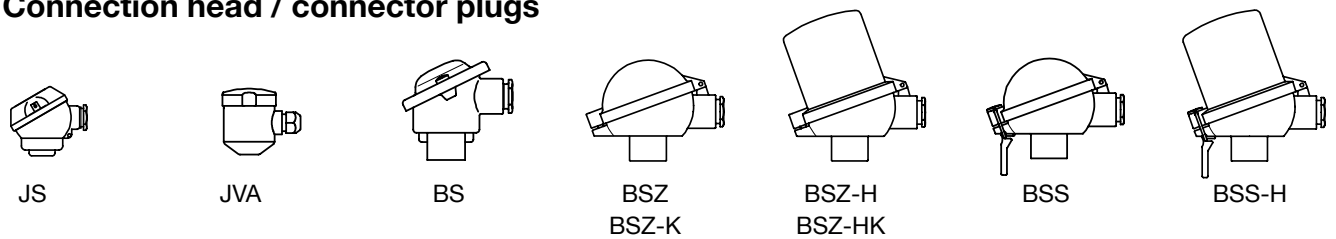

Model	Material	Cable entry	Ingress protection	Cap	Surface finish
<b>JS</b>	aluminium	M16 x 1.5	IP54	cap with 2 screws	silver bronze, painted
<b>JVA</b>	stainless steel	M12 x 1.5 <sup>1)</sup>	IP65	screw cover	blank
<b>BS</b>	aluminium	M20 x 1.5	IP65	cap with 2 screws	silver bronze, painted
<b>BSZ</b>	aluminium	M20 x 1.5	IP65	flap cap with screw	silver bronze, painted
<b>BSZ-K</b>	plastic	M20 x 1.5	IP65	flap cap with screw	blank
<b>BSZ-H</b>	aluminium	M20 x 1.5	IP65	flap cap with screw	silver bronze, painted
<b>BSZ-HK</b>	plastic	M20 x 1.5	IP65	flap cap with screw	blank
<b>BSS</b>	aluminium	M20 x 1.5	IP65	flap cap with clip	silver bronze, painted
<b>BSS-H</b>	aluminium	M20 x 1.5	IP65	flap cap with clip	silver bronze, painted

1) Cable gland, metal

- L-plug per DIN EN 175301-803 (IP65)
  - Circular connector M12 x 1 (IP65)
- see drawings on page 5

## Process connection

### Compression fitting

Allows simple adaptation to the required insertion length at the installation point

- Material: stainless steel
- Sealing ring material: stainless steel or PTFE

Sealing rings of stainless steel can be adjusted once, after unscrewing, sliding along the support tube is no longer possible.

Sealing rings of PTFE can be adjusted several times, after unscrewing, repeated sliding along the support tube is still possible.

- Max. temperature at process connection 150 °C

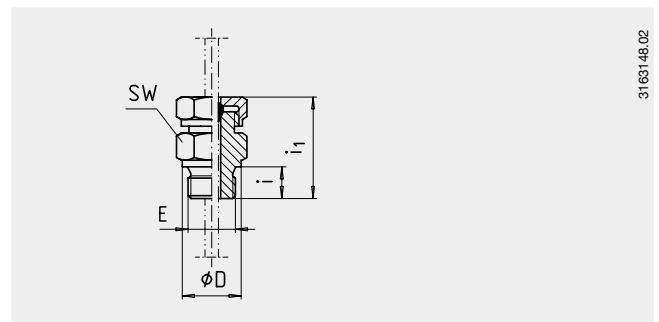

3163148.02

### Dimensions of process connections

Process connection	Male thread	Dimensions in mm			
	E	i	i <sub>1</sub>	ØD	SW
<b>Compression fitting</b>	G ¼ B <sup>1)</sup>	12	ca. 41	18	19
	G ⅜ B <sup>1)</sup>	12	ca. 41	22	22
	G ½ B	14	ca. 44	26	27

1) only with support tube diameter d = 6 mm

## Possible combinations of electrical connection, support tube / probe tip diameter, number of sensors and sensor method of connection

Electrical connection	Support tube/ probe tip Ø in mm	Sensor 1 x Pt100 Sensor method of connection			Sensor 2 x Pt100 Sensor method of connection		
		2 wire	3 wire	4 wire	2 wire	3 wire	4 wire
Connection head JS and JVA	6 / 3	x	x	x	x	-	-
Connection heads form B	8 / 6	x	x	x	x	x	x
L-plug per	6 / 3	x	x	-	-	-	-
DIN EN 175301-803	8 / 6	x	x	-	-	-	-
Circular connector M12 x 1	6 / 3	x	x	x	x	-	-
	8 / 6	x	x	x	x	-	-

## Support tube

Serves for the fastening of the compression fitting only and is open at the probe tip (not water-, dust- or gas-tight).

- Material: stainless steel

Support tube Ø in mm	Process connection	Maximum possible insertion length U <sub>1</sub> <sup>1)</sup> in mm with nominal length NL							
		65	75	80	85	105	125	230	250
6	G 1/4 B	25	35	40	45	55	85	190	210
6	G 3/8 B	-	-	-	45	55	85	190	210
8	G 1/2 B	-	-	-	-	-	85	190	210

1) spring not loaded, spring travel approx. 3 to 4 mm (tolerance of insertion lengths: ± 2 mm)

## Permissible temperature

- Application range: -50 °C ... +450 °C
- at the head: -40 °C ... +125 °C
- at the transmitter: -40 °C ... + 85 °C
- Storage: -40 °C ... + 60 °C

## Transmitter (option)

(not possible with connection head Model JS and JVA as well as instrument versions with connector plug)

Depending on used connection head a transmitter can be mounted into the thermometer.

- mounted instead of terminal block
- mounted within the cap of the connection head
- mounting not possible

Connection head	Transmitter					
	T12	T19	T24	T32	T42	T5350
JS	-	-	-	-	-	-
JVA	-	-	-	-	-	-
BS	-	○	○	-	-	○
BSZ / BSZ-K	○	○	○	○	○	○
BSZ-H / BSZ-HK	●	●	●	●	●	●
BSS	○	○	○	○	○	○
BSS-H	●	●	●	●	●	●

Model	Description	Explosion protection	Data sheet
T19	Analogue transmitter, configurable	without	TE 19.01
T24	Analogue transmitter, PC configurable	optional	TE 24.01
T12	Digital transmitter, PC configurable	optional	TE 12.01
T32	Digital transmitter, HART protocol	optional	TE 32.01
T42	Digital transmitter, PROFIBUS PA	optional	TE 42.01
T5350	Digital transmitter FOUNDATION Fieldbus and PROFIBUS PA	standard	TE 53.01

## Dimensions in mm

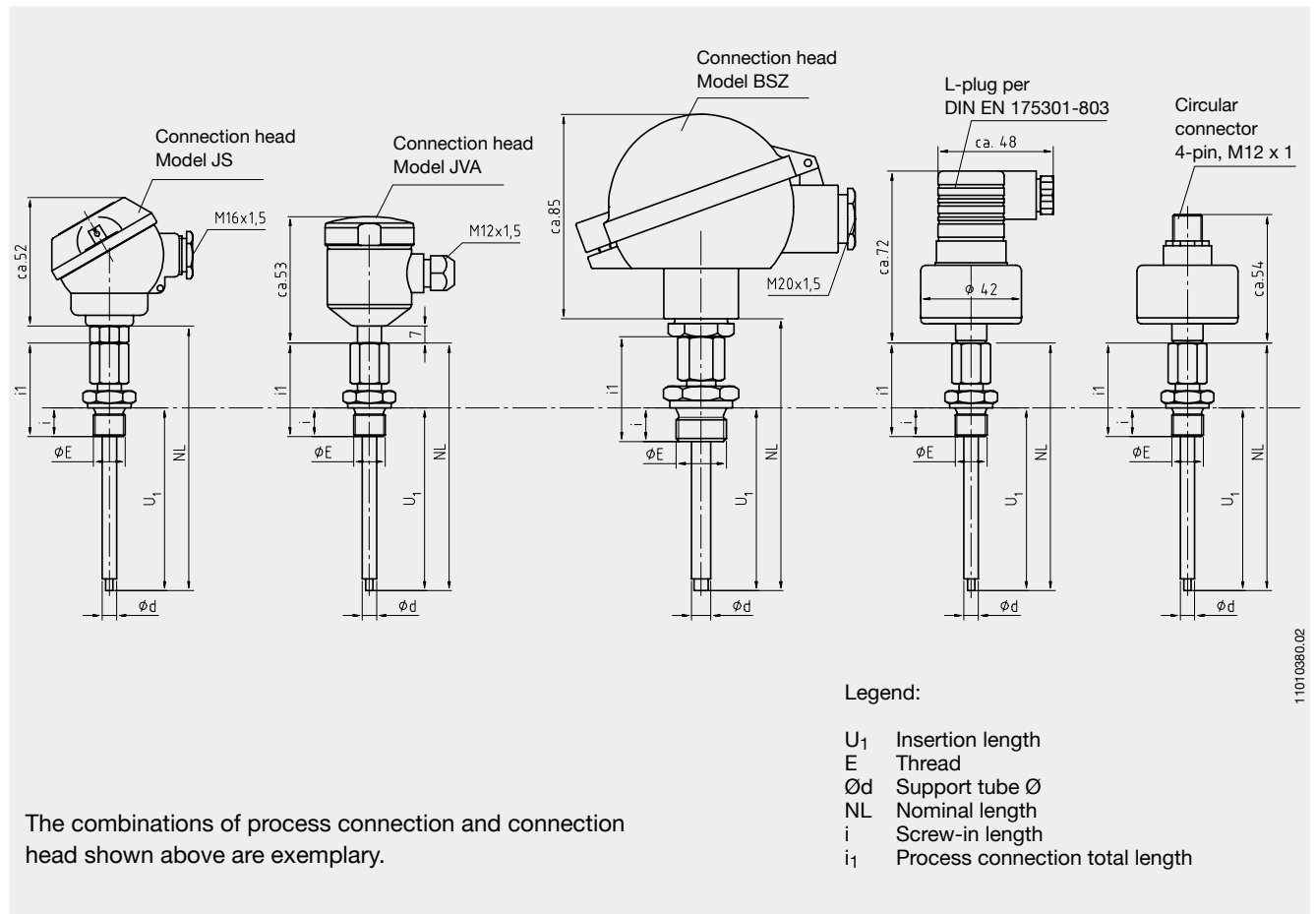

## Explosion protection (option)

Resistance thermometers of the Model series TR217 are available with a type examination certificate for "intrinsically safe" ignition protection (TÜV 02 ATEX 1793 X). These thermometers comply with the requirements of directive 94/9/EC (ATEX), EEx-i, for gases. Manufacturer's Declarations in accordance with EN 50 020 are also available. For applications in explosive atmospheres caused by dust a Manufacturer's Declaration in accordance with EN 50 281 is available (not for zone 20).

The classification / suitability of the instrument (permissible power P<sub>max</sub> and permissible ambient temperature) for the respective category can be seen on the type examination certificate and in the operating instructions.

Built-in transmitters have their own approval. The permissible ambient temperature ranges of the built-in transmitters can be taken from the corresponding transmitter approval.

Explosion protection for:	Zone	Connection head							Connector plug	
		JS	JVA	BS	BSZ BSZ-K	BSZ-H BSZ-HK	BSS	BSS-H	L-plug	Circular connector
<b>Gases</b>	0 1)	ia	ia	ia	ia	ia	ia	ia	ia	ia
	1	ib	ib	ib	ib	ib	ib	ib	ib	ib
	2	ib	ib	ib	ib	ib	ib	ib	ib	ib
<b>Dusts 2)</b>	20	-	-	-	-	-	-	-	-	-
	21	-	ib	ib	ib	ib	ib	ib	ib	ib
	22	-	ib	ib	ib	ib	ib	ib	ib	ib

1) The instrument is not suitable for the separation of Ex-Zones.

2) When using the thermometer in explosive atmospheres caused by dust, the plant manager absolutely has to ensure that no explosive medium gets into contact with the probe tip.

# Electrical connection

## Connection heads JS and JVA

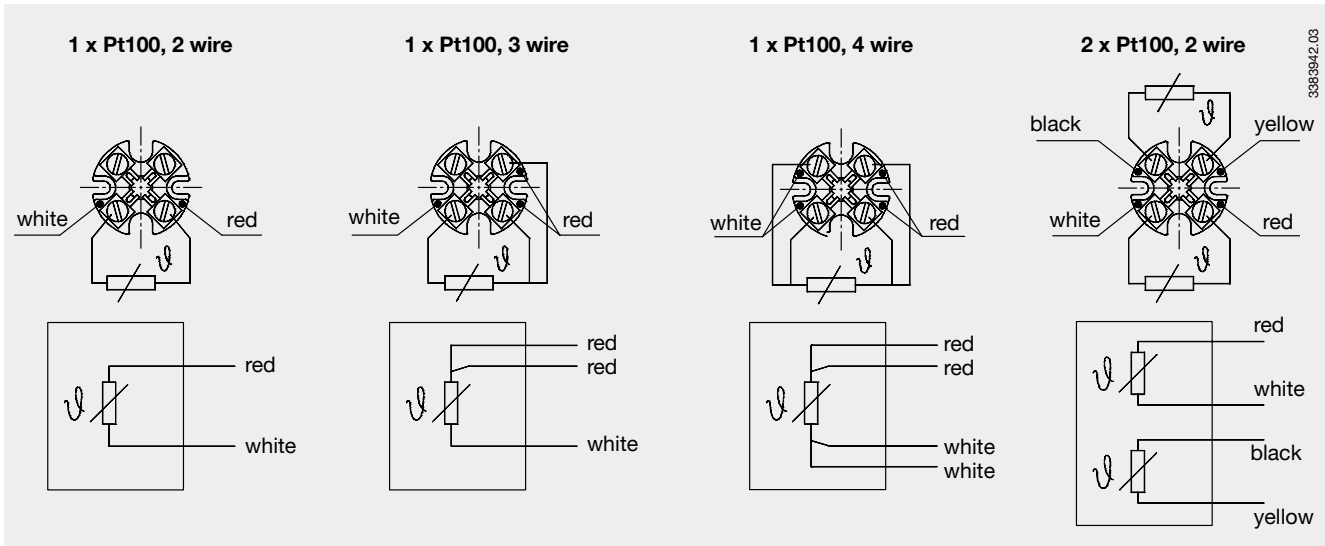

3383942.03

## Connection heads form B

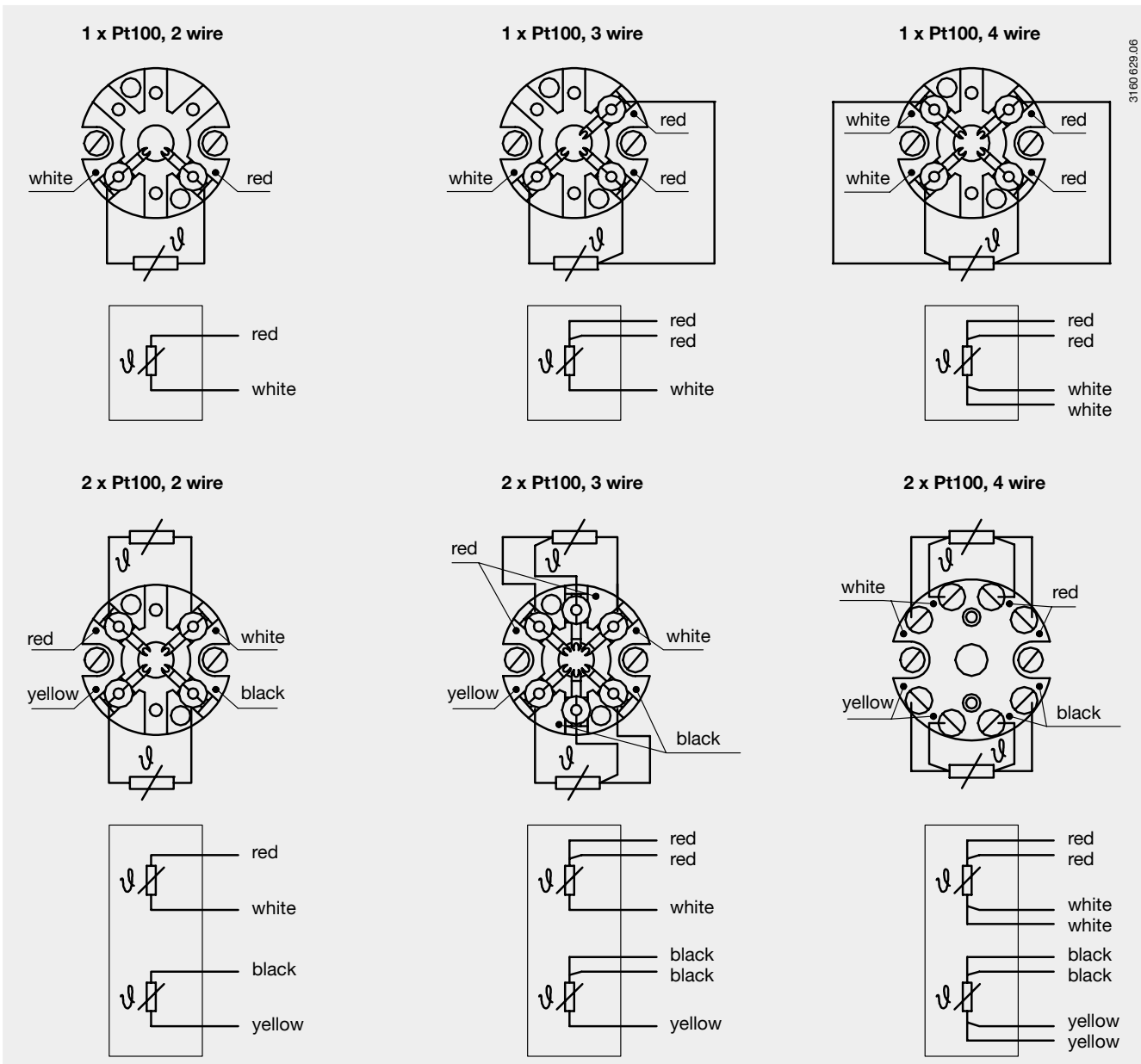

3160 629.06

## Connector plugs

L-plug per  
DIN EN 175301-803

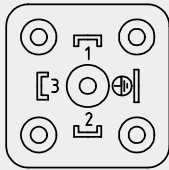

1 x Pt 100,  
2 wire

green brown

2 1

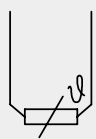

1 x Pt 100,  
3 wire

green yellow brown

2 3 1

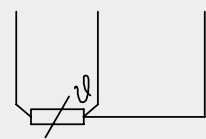

Circular connector  
4-pin, M12 x 1



1 x Pt 100,  
2 wire

brown black

1 4

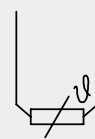

1 x Pt 100,  
3 wire

brown blue black

1 3 4

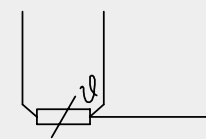

1 x Pt 100,  
4 wire

brown white blue black

1 2 3 4

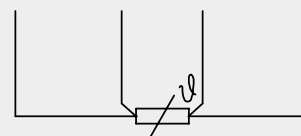

2 x Pt 100,  
2 wire

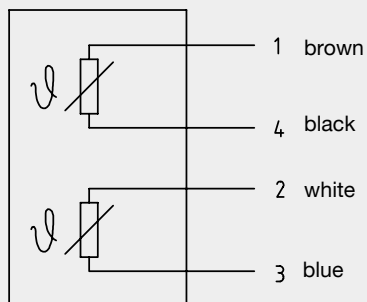

Specifications and dimensions given in this leaflet represent the state of engineering at the time of printing.  
Modifications may take place and materials specified may be replaced by others without prior notice.



**WIKAI Alexander Wiegand GmbH & Co. KG**  
Alexander-Wiegand-Straße 30  
63911 Klingenberg/Germany  
Phone (+49) 93 72/132-0  
Fax (+49) 93 72/132-406  
E-Mail [info@wika.de](mailto:info@wika.de)  
[www.wika.de](http://www.wika.de)