

# Thread Mounted Thermocouples Model TC201, with Fabricated Thermowell

WIKA Data Sheet TE 65.15

## Applications

- Machinery, plant and tank construction
- Energy and power plant technology
- Chemical industry
- Food and beverage industry
- Sanitary, heating and air-conditioning technology

## Special Features

- Application ranges from 0 °C to +1200 °C
- Fabricated thermowell included
- Measuring insert exchangeable
- Intrinsically safe versions (ATEX)

## Description

Thermocouples in this series are designed for direct screw fitting into the process, mainly in tanks and pipelines.

These thermometers are suitable for fluid and gaseous media under moderate mechanical load and normal chemical stress. The thermowell made of stainless steel is fully welded and screw-fitted into the connection head. The spring loaded measuring insert can be exchanged without removing the complete probe from the process. This makes inspection and, when servicing is necessary, replacement possible during operation and while the plant is running. Selection of normal or standard lengths enables short delivery time and the possibility of stocking spare components.

Insertion length, process connection, design of thermowell, connection head as well as type, number and accuracy of sensors can be selected individually for the respective application.



**Thread Mounted Thermocouple with Fabricated Thermowell, Model TC201**

Intrinsically safe designs are available for applications in hazardous areas. The models of the TC201 series are provided with a type test certificate for "intrinsically safe" type of protection according to guideline 94/9/EC (ATEX), EEx-i, for gases and dust. ATEX Manufacturer Declaration of Conformity in accordance with EN 50 020 is also available.

Optionally we can fit analogue or digital transmitters from the WIKA range into the connection head of the TC201.

# Sensor

## Sensor type

Type	Recommended max. operating temperature
<b>K (NiCr-Ni)</b>	1200 °C
<b>J (Fe-CuNi)</b>	800 °C
<b>E (NiCr-CuNi)</b>	800 °C
<b>T (Cu-CuNi)</b>	400 °C
<b>N (NiCrSi-NiSi)</b>	1200 °C

In the case of type K there is a risk of blue mould between 850 °C and 950 °C. We recommend the use of a sensor type N, if the working temperature fluctuates continuously in this range.

The application range of these thermometers is limited by the permissible max. temperature of the thermocouple as well as the max. temperature of the thermowell material.

Listed sensor types are available both as simplex or duplex thermocouples.

The measuring point (hot junction) of the probe is supplied as ungrounded unless specified otherwise.

### Sensor limiting error

A cold junction temperature of 0 °C is taken as basis with the definition of the sensor limiting error of thermocouples.

### Type K

Class	Temperature range	Limiting error
<b>DIN EN 60584 part 2</b>		
1	-40 °C ... +375 °C	± 1.5 °C
1	+375 °C ... +1000 °C	± 0.0040 •  t  <sup>1)</sup>
2	-40 °C ... +333 °C	± 2.5 °C
2	+333 °C ... +1200 °C	± 0.0075 •  t  <sup>1)</sup>
<b>ANSI MC96.1</b> (for information only, standard is cancelled)		
Standard	0 °C ... +1250 °C	± 2.2 °C or <sup>2)</sup> ± 0.75 %
Special	0 °C ... +1250 °C	± 1.1 °C or <sup>2)</sup> ± 0.4 %

### Type J

Class	Temperature range	Limiting error
<b>DIN EN 60584 part 2</b>		
1	-40 °C ... +375 °C	± 1.5 °C
1	+375 °C ... +750 °C	± 0.0040 •  t  <sup>1)</sup>
2	-40 °C ... +333 °C	± 2.5 °C
2	+333 °C ... +750 °C	± 0.0075 •  t  <sup>1)</sup>
<b>ANSI MC96.1</b> (for information only, standard is cancelled)		
Standard	0 °C ... +750 °C	± 2.2 °C or <sup>2)</sup> ± 0.75 %
Special	0 °C ... +750 °C	± 1.1 °C or <sup>2)</sup> ± 0.4 %

### Type E

Class	Temperature range	Limiting error
<b>DIN EN 60584 part 2</b>		
1	-40 °C ... +375 °C	± 1.5 °C
1	+375 °C ... +800 °C	± 0.0040 •  t  <sup>1)</sup>
2	-40 °C ... +333 °C	± 2.5 °C
2	+333 °C ... +900 °C	± 0.0075 •  t  <sup>1)</sup>

### Type T

Class	Temperature range	Limiting error
<b>DIN EN 60584 part 2</b>		
1	-40 °C ... +125 °C	± 0.5 °C
1	+125 °C ... +350 °C	± 0.0040 •  t  <sup>1)</sup>
2	-40 °C ... +133 °C	± 1.0 °C
2	+133 °C ... +350 °C	± 0.0075 •  t  <sup>1)</sup>

### Type N

Class	Temperature range	Limiting error
<b>DIN EN 60584 part 2</b>		
1	-40 °C ... +375 °C	± 1.5 °C
1	+375 °C ... +1000 °C	± 0.0040 •  t  <sup>1)</sup>
2	-40 °C ... +333 °C	± 2.5 °C
2	+333 °C ... +1200 °C	± 0.0075 •  t  <sup>1)</sup>

1) |t| is the value of the temperature in °C without consideration to the sign  
2) Whichever is larger.

Limiting error with selected temperatures in °C for thermocouples type K and type J

Temperature (ITS 90) °C	Limiting error DIN EN 60584	
	Class 1 °C	Class 2 °C
0	± 1.5	± 2.5
100	± 1.5	± 2.5
200	± 1.5	± 2.5
300	± 1.5	± 2.5
400	± 1.6	± 3
500	± 2	± 3.75
600	± 2.4	± 4.5
700	± 2.8	± 5.25
800	± 3.2	± 6
900	± 3.6	± 6.75
1000	± 4	± 7.5
1100	± 4.4	± 8.25
1200	± 4.8	± 9

## TC201 components

Fig. with parallel thread, conical thread see page 4

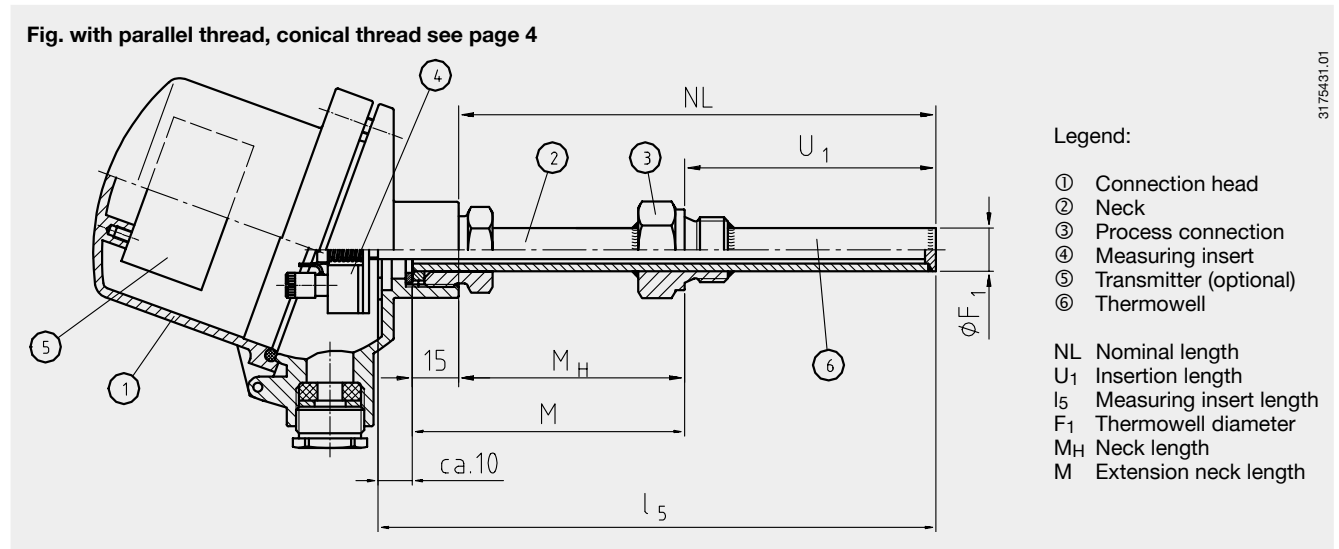

3175431.01

### Connection head

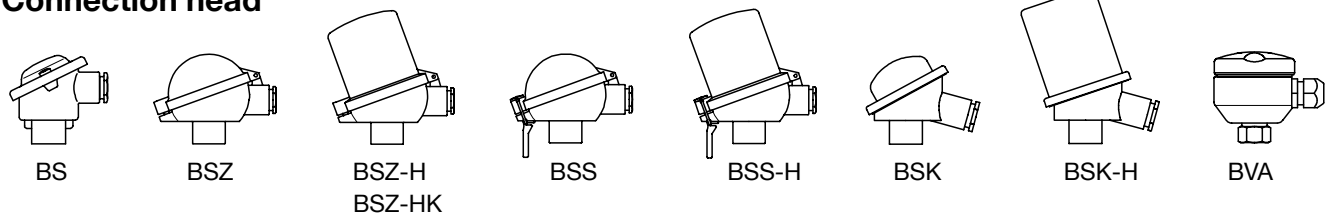

Model	Material	Cable entry	Ingress protection	Cap	Surface finish
<b>BS</b>	aluminium	M20 x 1.5	IP54	cap with 2 screws	silver bronze, painted
<b>BSZ</b>	aluminium	M20 x 1.5	IP65	flap cap with screw	silver bronze, painted
<b>BSZ-H</b>	aluminium	M20 x 1.5	IP65	flap cap with screw	silver bronze, painted
<b>BSZ-HK</b>	plastic	M20 x 1.5	IP65	flap cap with screw	blank
<b>BSS</b>	aluminium	M20 x 1.5	IP65	flap cap with clip	silver bronze, painted
<b>BSS-H</b>	aluminium	M20 x 1.5	IP65	flap cap with clip	silver bronze, painted
<b>BSK</b>	plastic	M20 x 1.5	IP54	screw cover	blank
<b>BSK-H</b>	plastic	M20 x 1.5	IP54	screw cover	blank
<b>BVA</b>	stainless steel	M20 x 1.5	IP65	screw cover	blank

### Connection head with digital indicator (option)

As an optional alternative to the standard connection head the thermometer may be equipped with the digital indicator DIH10. The connection head used in this case is similar to the head model BSZ-H.

For operation a 4 ... 20 mA transmitter is necessary, which is mounted to the measuring insert. The scale range of the indicator is configured identical to the measuring range of the transmitter.

Intrinsically safe versions, explosion protection type EEx-i, are also available.

### Transmitter (option)

Depending on used connection head a transmitter can be mounted into the thermometer (head mount).

- mounted instead of connection socket
- mounted within the cap of the connection head
- mounting not possible
- x mounted in the cap of the connection head, using a mounting bracket

Mounting of two transmitters on request.

Connection head	Transmitter			
	T12	T19	T32	T42
<b>BS</b>	–	○	–	–
<b>BSZ</b>	○	○	○	○
<b>BSZ-H / BSZ-HK</b>	●	●	●	●
<b>BSS</b>	○	○	○	○
<b>BSS-H</b>	●	●	●	●
<b>BSK</b>	–	○	–	–
<b>BSK-H</b>	x	x	x	x
<b>BVA</b>	○	○	○	○

## Thermowell

The thermowell is made of drawn tube with welded bottom and screwed into the connection head. The cable entry of the connection head can be aligned.

The process connection is welded onto the thermowell in the factory to customer's own specifications. This also determines the insertion length. Preference is to be given to insertion lengths to DIN Standards, respectively.

Designs to DIN Standards as well as special designs (for example, with tapered thermowell, reinforced extension neck, etc.) are available in stainless steel 1.4571 or special materials on request.

### Design of thermowell

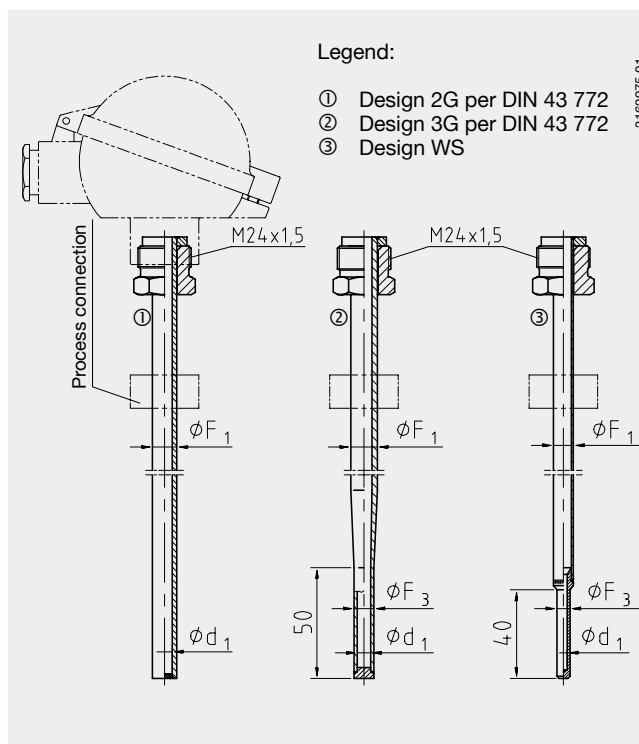

## Dimensions in mm

### Versions according to DIN 43 772

Design	Insertion length	Process connection	Thermowell outer Ø F <sub>1</sub>	Thermowell outer Ø at tip F <sub>3</sub>	Thermowell inner Ø at tip d <sub>1</sub>	Neck length M <sub>H</sub>
Form 2G	160	G ½ B, G 1 B	9, 11, 12, 14	-	-	130
Form 2G	250	G ½ B, G 1 B	9, 11, 12, 14	-	-	130
Form 2G	400	G ½ B, G 1 B	9, 11, 12, 14	-	-	130
Form 3G	160	G ½ B, G 1 B	12	9 + 0.2	6 + 0.1 / - 0.05	132
Form 3G	220	G ½ B, G 1 B	12	9 + 0.2	6 + 0.1 / - 0.05	132
Form 3G	280	G ½ B, G 1 B	12	9 + 0.2	6 + 0.1 / - 0.05	132
Form 3G	160	G ½ B, G 1 B	14	11 + 0.2	8 + 0.1 / - 0.05	132
Form 3G	220	G ½ B, G 1 B	14	11 + 0.2	8 + 0.1 / - 0.05	132
Form 3G	280	G ½ B, G 1 B	14	11 + 0.2	8 + 0.1 / - 0.05	132

Above types are also available with process connection ½ NPT. These do not correspond, however, to the DIN 43 772.

### Non-standardised versions

Design	Insertion length	Process connection	Thermowell outer Ø F <sub>1</sub>	Thermowell outer Ø at tip F <sub>3</sub>	Thermowell inner Ø at tip d <sub>1</sub>	Neck length M <sub>H</sub>
Form WS	160	G ½ B, G 1 B, ½ NPT	9, 11, 12	6	3.5	130
Form WS	220	G ½ B, G 1 B, ½ NPT	9, 11, 12	6	3.5	130
Form WS	250	G ½ B, G 1 B, ½ NPT	9, 11, 12	6	3.5	130
Form WS	280	G ½ B, G 1 B, ½ NPT	9, 11, 12	6	3.5	130
Form WS	400	G ½ B, G 1 B, ½ NPT	9, 11, 12	6	3.5	130

## Process connection

Design:

- Male thread, welded with thermowell
- Compression fitting, with thermowell diameter 12 mm preferably  
(Compression fittings allow simple adaptation to the required insertion length at the installation point. After tightening, the compression fitting can no longer be moved on the thermowell.)
- Union nut

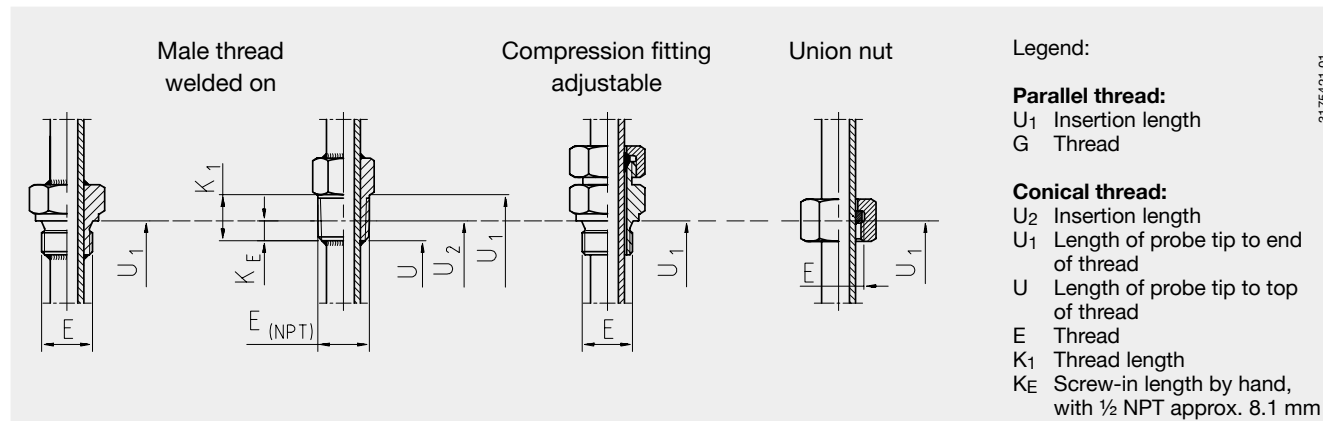

Process connection	Thermowell Ø			
	9 mm	11 mm	12 mm	14 mm
Male thread	G $\frac{1}{2}$ B	G $\frac{1}{2}$ B	G $\frac{1}{2}$ B	G $\frac{1}{2}$ B
	-	G 1 B	G 1 B	G 1 B
	$\frac{1}{2}$ NPT	$\frac{1}{2}$ NPT	$\frac{1}{2}$ NPT	$\frac{1}{2}$ NPT
Compression fitting	-	-	G $\frac{1}{2}$ B	-
	-	-	$\frac{1}{2}$ NPT	-
Union nut	G $\frac{1}{2}$ B	G $\frac{1}{2}$ B	G $\frac{1}{2}$ B	G $\frac{1}{2}$ B

## Measuring insert

The measuring insert is made of a vibration-resistant sheathed measuring cable (MI cable). In order to ensure that the measuring insert is firmly pressed down on the thermowell bottom the insert is spring-loaded (spring travel: max 10 mm). The standard material used for the measuring insert sheath is stainless steel. Other materials may be offered on inquiry.

If service is required, please pay attention to the following:  
 The diameter of the measuring insert shall be approx. 1 mm smaller than the hole diameter of the thermowell. Gaps of more than 0.5 mm between thermowell and measuring insert will have a negative effect on the heat transfer, and they will result in an unfavourable response behaviour of the thermometer.

### Standard measuring insert length

Measuring insert Ø in mm	Standard measuring insert length in mm											
	275	315	345	375	405	435	525	555	585	655	735	
<b>3</b>	275	315		375		435						
<b>6</b>	275	315	345	375	405	435	525	555	585	655	735	
<b>8</b>	275	315	345	375	405	435	525	555	585	655	735	

## Electrical connection

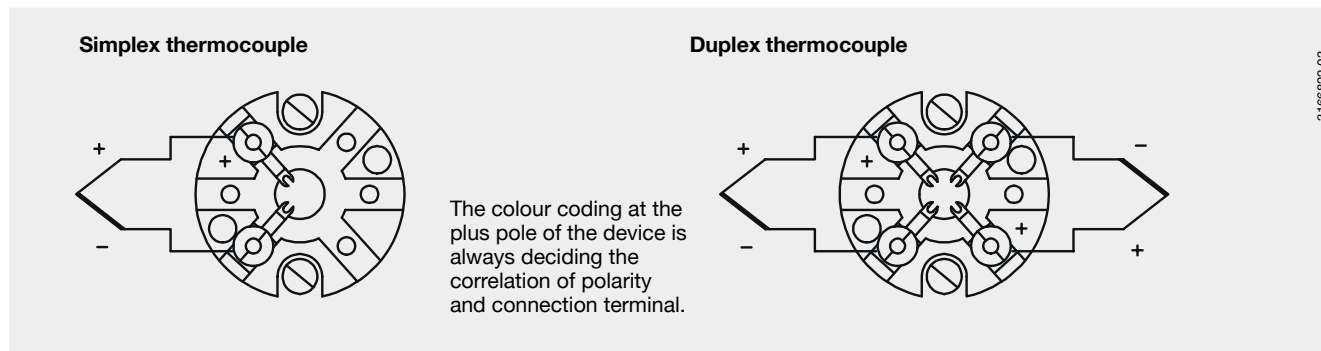

## Explosion protection (option)

Thermocouples TC201 are available with a type test certificate for "intrinsic safety" type of ignition protection (TÜV 02 ATEX 1793 X). These thermometers comply with the requirements of directive 94/9/EC (ATEX), EEx-i, for gases and dust.

The classification / suitability of the instrument (permissible power  $P_{max.}$ , minimum neck length and permissible ambient temperature) for the respective category can be seen from the type test certificate and the operating instructions.

The responsibility for using suitable thermowells rests with the user.

The permissible ambient temperature ranges of the built-in transmitters can be taken from the corresponding transmitter approval.

## Ordering information

Field No.	Code	Features
		<b>Explosion protection</b>
	Z	without
	Y	according to directive 94/9/EC (ATEX) EEx-i G for gases <sup>1)</sup>
1	H	according to directive 94/9/EC (ATEX) EEx-i D for dust <sup>1)</sup>
		<b>Type and number of sensors</b>
	A	1 x type K (NiCr-Ni)
	B	2 x type K (NiCr-Ni) <sup>1)</sup>
	C	1 x type J (Fe-CuNi)
	D	2 x type J (Fe-CuNi) <sup>1)</sup>
2	?	other <i>please state as additional text</i>
		<b>Sensor limiting error</b>
	2	class 2 per DIN EN 60 584
	1	class 1 per DIN EN 60 584
3	?	other <i>please state as additional text</i>
		<b>Measuring point</b>
	1	insulated
4	2	not insulated
		<b>Process connection</b>
	GD	G ½ B
	GF	G 1 B
	ND	½ NPT
5	??	other <i>please state as additional text</i>
		<b>Design of process connection</b>
	G	male thread
	K	compression fitting <i>preferably with thermowell diameter 12 mm</i>
6	?	other <i>please state as additional text</i>
		<b>Thermowell material</b>
	1	stainless steel 1.4571
7	?	other <i>please state as additional text</i>
		<b>Thermowell outer diameter</b>
	3	6 mm
	4	9 mm <i>form 2G accordig to DIN 43772</i>
	6	11 mm <i>form 2G accordig to DIN 43772</i>
	7	12 mm <i>form 2G accordig to DIN 43772</i>
	B	9 mm, tapered to 6 mm (with weld on tip)
	C	11 mm, tapered to 6 mm (with weld on tip)
	G	12 mm, tapered to 9 mm (with hammered tip) <i>form 3G accordig to DIN 43772</i>
8	?	other <i>please state as additional text</i>
		<b>Insertion length</b>
	0160	160 mm <i>Standard insertion length with neck length 130 mm (form 2G per DIN 43772)</i>
	0250	250 mm <i>Standard insertion length with neck length 130 mm (form 2G per DIN 43772)</i>
	0400	400 mm <i>Standard insertion length with neck length 130 mm (form 2G per DIN 43772)</i>
	0220	220 mm <i>Standard insertion length with neck length 132 mm (form 3G per DIN 43772)</i>
	0280	280 mm <i>Standard insertion length with neck length 132 mm (form 3G per DIN 43772)</i>
9		length in mm, e.g. 0850 for 850 mm
		<b>Neck length</b>
	2	130 mm <i>standard neck tube for straight thermowells, form 2G per DIN 43772</i>
	E	132 mm <i>standard neck tube for thermowells with hammered tip, form 3G per DIN 43772</i>
10	?	other <i>please state as additional text</i>
		<b>Connection head</b>
	1	model BS (aluminium) <i>only transmitter T19 as option possible</i>
	2	model BSZ (aluminium)
	3	model BSZ-H (aluminium) <i>mounting of an optional transmitter in the cap possible</i>
	S	model BSZ-HK (plastic) <i>mounting of an optional transmitter in the cap possible</i>
	4	model BSS (aluminium)
	5	model BSS-H (aluminium) <i>mounting of an optional transmitter in the cap possible</i>
	6	model BSK (plastic) <i>only without explosion protection</i>
	7	model BSK-H (plastic) <i>only without explosion protection</i>
	8	model BVA (stainless steel)
	H	BSZ-H with digital temperature indicator DIH10 (set to transmitter range) <i>only without explosion protection, for use a transmitter (4...20 mA) is required</i>
	J	BSZ-H with digital temperature indicator DIH10-Ex (set to transmitter range) <i>for use a transmitter (4...20 mA) in Ex-version is required</i>
11	?	other <i>please state as additional text</i>

## Ordering information, continued

Field No.	Code	Features	
		<b>Cable entry to connection head</b>	
12	4	M20 x 1.5	
	?	other <span style="float: right;"><i>please state as additional text</i></span>	
		<b>Transmitter</b>	
13	ZZ	without	
	TA	mounted on the measuring insert	
	TB	mounted in the cup of the connection head	
		<b>Additional order info</b>	
14	YES	NO	
	T	Z	quality certificates <span style="float: right;"><i>see price list</i></span>
15	T	Z	additional text <span style="float: right;"><i>Please state as clearly understandable text!</i></span>

1) Designs with explosion protection: The combination of duplex thermocouple / transmitter is permissible only with connection head BSZ-H, BSZ-HK or BSS-H.

### Order code:

	1	2	3	4	5	6	7	8	9	10	11	12	13	14	15		
TC201 -	□	□	□	□	□	□	□	□	□	□	□	□	□	□	□		
														ZZ	-	□	□

**Additional text:** \_\_\_\_\_

Specifications and dimensions given in this leaflet represent the state of engineering at the time of printing. Modifications may take place and materials specified may be replaced by others without prior notice.

