

Electronic Pressure Switches

Model PS-20, standard vesion

Model PS-21, flush diaphragm

WIKA Data Sheet PE 81.28

Applications

- Mechanical engineering
- Hydraulics / Pneumatics
- Level measuring

Special Features

- Pressure ranges from 0 ... 0.25 bar to 0 ... 1000 bar
- Case and wetted parts of stainless steel
- Various process connections
- 1 or 2 variably configurable switches
- Ingress protection IP 65 up to IP 68

Description

The main features of the pressure switches are their good long-term stability as well as their sturdy and compact design. They are used in level measuring, pressure control of engines, pumps, filters, compressors, hydraulic and pneumatic control systems. Power supply of the pressure switches may be by means of non-stabilized DC 10 ... 30 V. Up to two switching points are available.

Factory-made programming

A main advantage of the pressure switches for the use as OEM-component is the configuration of the switching types (e.g. closing or opening switching point and switching hysteresis) already in the factory according to customer specifications. Adjustments cannot be carried out by unauthorised persons.

Programming on site via PC

When needed the user can adjust the switching parameters via the optionally available programming module. The programming module comes together with a connecting



Fig. left Pressure Switch PS-20

Fig. center Pressure Switch PS-20 / programming module

Fig. right Pressure Switch PS-21

cable for the pressure switch, an RS 232 cable to the PC and the software Easy Switch. The parameters can easily be set via PC under Windows within a few seconds.

Shock and vibration resistant

As there are absolutely no mechanical components like potentiometers, hand-actuated auxiliary switches etc. a passive deviation of the settings can be excluded even under the most extreme shock and vibration strains.

Electric connection of the pressure switch is carried out via a 5-pin circular connector or flying lead.

Pressure switches with one switching output only can be obtained with a L-connector according to DIN 175301-803.

All wetted parts are made of stainless steel and are completely welded to exclude possible conflict between soft sealing material and the measured medium. The compact case is also made of stainless steel and provides IP 65 protection as standard.

Specification

Model PS-20 / PS-21

Pressure ranges	bar	0.25	0.4	0.6	1	1.6	2.5	4	6	10	16
Over pressure safety	bar	2	2	4	5	10	10	17	35	35	80
Burst pressure	bar	2.4	2.4	4.8	6	12	12	20.5	42	42	96
Pressure ranges	bar	25	40	60	100	160	250	400	600	1000 ¹⁾	
Over pressure safety	bar	50	80	120	200	320	500	800	1200	1500	
Burst pressure	bar	96	400	550	800	1000	1200	1700 ²⁾	2400 ²⁾	3000	
		{Vacuum, gauge pressure, compound range, absolute pressure are available}									
Materials		(other materials see WIKA diaphragm seal programm)									
■ Wetted parts		Stainless steel									
➤ Model PS-20		Stainless steel {Hastelloy C4}; O-ring: NBR {FPM/FKM or EPDM}									
➤ Model PS-21		Stainless steel									
■ Case		Stainless steel									
internal transmission fluid		Synthetic oil (only for pressure ranges up to 0 ... 25 bar or flush diaphragm units) {Halocarbon oil for oxygen applications} ³⁾ {Listed by FDA for food industry}									
Power supply U_B	DC V	10 (12) < U_B ≤ 30 (using the programming module)									
Type of switch		A	B	C	D	E	F				
Number of switching points		1	1	2	2	2	1				
Switching current (max. DC 30 V)		4	0.3	2	0.3	0.3	0.3				
Mode of connection		PNP	NPN	PNP/PNP	NPN/NPN	PNP/NPN	potentialfree (Opto-Relay)				
Switch		NC or NO									
■ Function		NC or NO									
■ Adjustment of											
Switching points	% of span	0 ... 100									
■ Switching hysteresis	% of span	1 ... 99									
■ Switching window	% of span	0 ... 100									
■ Default values	low / high	are set at latest 20 ms after the instrument has been switched on ⁴⁾									
■ Damping	ms	0 ... 500									
■ Manufacturer's settings		when selected via the software the manufacturer's values are activated									
■ Switching time	ms	≤ 6 for switch type A and C									
	ms	≤ 10 for switch type B, D, E and F									
Accuracy adjustment of											
switching points	% of span	≤ 1.0 (limit point calibration)									
	% of span	≤ 0.5 (BFSL)									
Reproducibility	% of span	≤ 0.25									
1-year stability	% of span	≤ 0.2 (at reference conditions)									
Permissible temperature ranges											
■ Medium		-30 ... +100 °C {-40 ... +125 °C}					-22 ... +212 °F {-40 ... +257 °F}				
■ Ambient		-20 ... + 80 °C					-4 ... +176 °F				
■ Storage		-40 ... +100 °C					-40 ... +212 °F				
Compensated temp. range		0 ... + 80 °C					+32 ... +176 °F				
Temperature coefficients in											
compensated temp. range											
■ Mean TC of zero	% of span	± 1.0									
■ Mean TC of span	% of span	± 1.0									
CE- conformity		89/336/EWG interference emission and immunity see EN 61 326 97/23/EG Pressure equipment directive									
Shock resistance	g	500 according to IEC 60068-2-27 (mechanical shock)									
Vibration resistance	g	10 according to IEC 60068-2-26 (vibration under resonance)									
Wiring protection		Supply circuit protection against crossed polarity; overvoltage protection Short circuit protection for model A and C									
Ingress protection per		IEC 60529 / EN 60529, see page 3									
Weight	kg	Approx. 0.2									

1) Only Model PS-20.

2) For Model PS-21: the value specified in the table applies only when sealing is realised with the sealing ring underneath the hex. Otherwise max. 1500 bar applies.

3) Media temperature for oxygen version: -30 ... +60 °C / -22 ... 140 °F (PS-21 up to max. 160 bar). Cannot be manufactured for absolute pressure ranges < 1 bar abs.

4) This guarantees a clear definition of the switching state, when the instrument is switching on within the hysteresis pressure range.

{ } Items in curved brackets are optional extras for additional price.

Dimensions in mm

Electrical connections

Circular connector,
5-pin M 12x1,
IP 67
Order code: M5

L-connector ¹⁾
DIN EN 175301-803,
IP 65
Order code: A4

{Flying leads}
IP 67
Order code: DL

{Flying leads, zero/span not
adjustable}
IP 68
Order code: EM

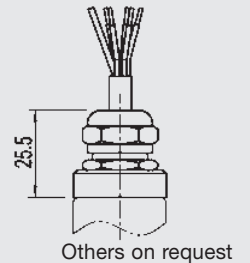
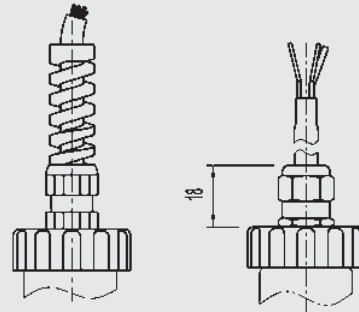
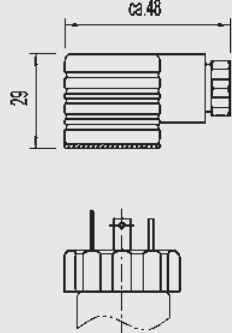
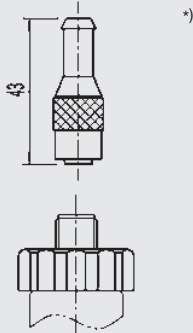

Case

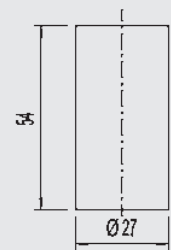
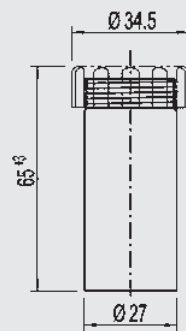

Pressure connections PS-20

G 1/2 B
EN 837
Order code: GD

G 1/4
EN 837
Order code: GB

1/2 NPT
per „Nominal size for US
standard tapered pipe thread
NPT“
Order code: ND

1/4 NPT
per „Nominal size for US
standard tapered pipe thread
NPT“
Order code: NB

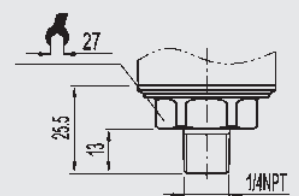
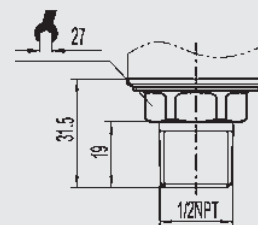
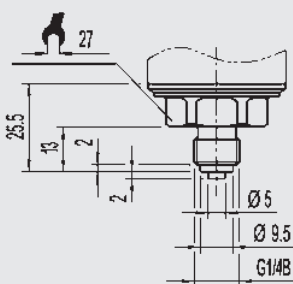
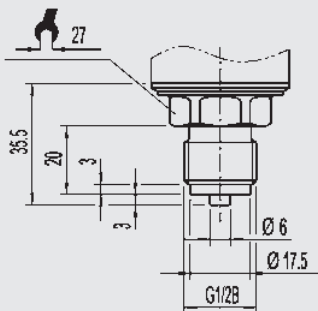

Others on request

Pressure connections PS-21

G 1B
0 ... 0.25 up to 0 ... 1.6 bar
Order code: 85

G 1/2 B
0 ... 2.5 up to 0 ... 600 bar
Order code: 86

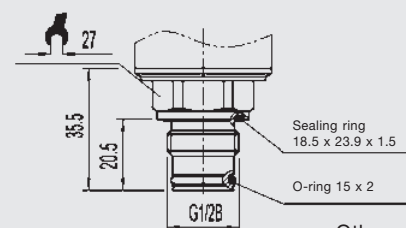
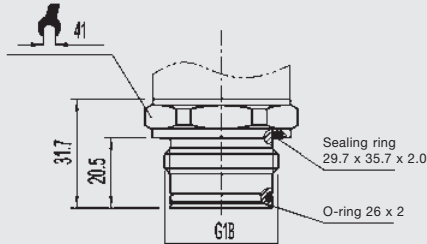

Others on request

For tapped holes and welding sockets please see data sheet IN 00.14 or www.wika.de/download

^{*)} Connectors are not included in delivery

¹⁾ max. 1 switch

{ } Items in curved brackets are optional extras for additional price.

Electrical connections

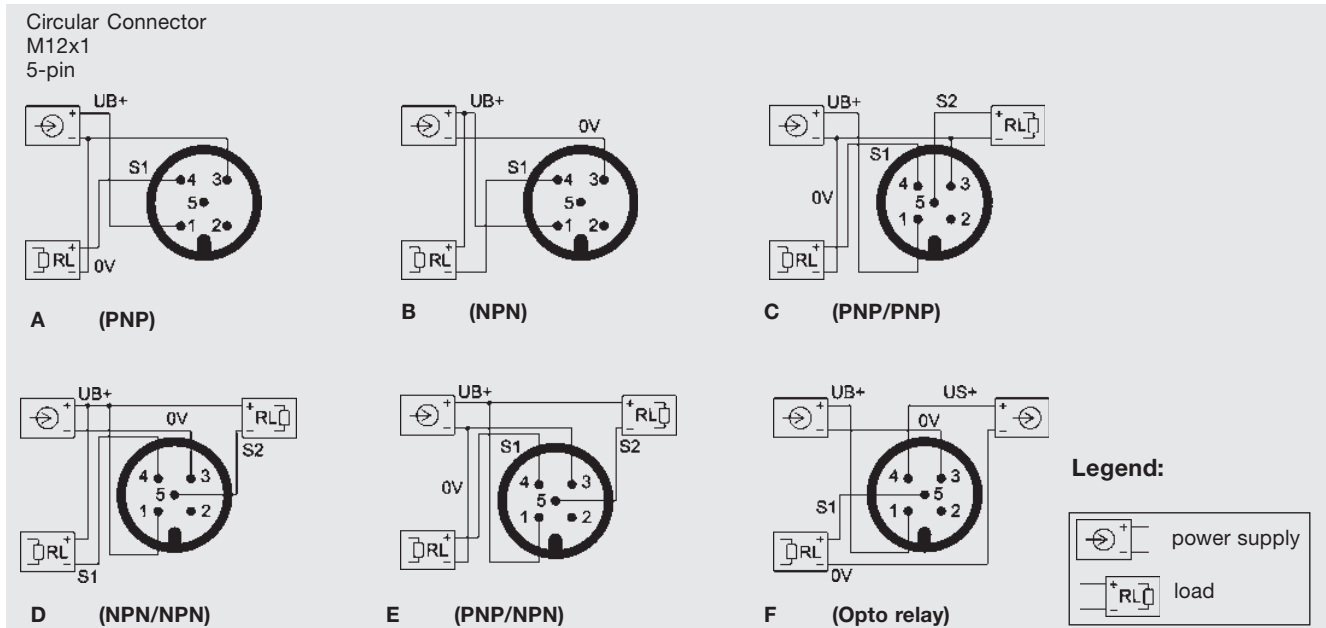

configuration	flying leads	L-connector	locking plug M 12 x 1
power supply (U_{B+})	brown	1	1
0 V	green	2	3
switch (S 1)	white	3	4
switch (S 2)	yellow	-	5

Manufacturer's settings:

Manufacturer's settings of the switching points per switch, when not specified by the customer and when the programming module is included into the order:

Switch 1 (S1):	Opening	
	Switching point 1:	40% of span
	Switching point 2:	60% of span
	Damping:	0 ms
	Default settings SO1:	
	Type 0 =	closed
	Type 1 =	open
	Type 2 =	closed
	Type 3 =	open
Switch 2 (S2):	Closing	
	Switching point 1:	40% of span
	Schaltpunkt 2:	60% of span
	Dämpfung:	0 ms
	Default settings SO1:	
	Type 0 =	closed
	Type 1 =	open
	Type 2 =	closed
	Type 3 =	open

Order details:

When ordering pressure switches with customer-specific programming please send us the following information.

Switch S1		
Switching hysteresis	or Switching window	
0 = opening 1 = closing	2 = Low-window 3 = High-window	<input type="text"/>
Pressure value for lower switching point SP1		<input type="text"/>
Pressure value for higher switching point SP2		<input type="text"/>
Default setting after power cut A = open / B = closed		<input type="text"/>
Damping value (0 ms / 20 ms / 100 ms / 200 ms / 500 ms)		<input type="text"/>
Switch S2 (not available for Type A, B and F)		
Switching hysteresis		
or Switching window		
0 = opening 1 = closing	2 = Low-window 3 = High-window	<input type="text"/>
Pressure value for lower switching point SP1		<input type="text"/>
Pressure value for higher switching point SP2		<input type="text"/>
Default setting after power cut A = open / B = closed		<input type="text"/>
Damping value (0 ms / 20 ms / 100 ms / 200 ms / 500 ms)		<input type="text"/>

Specifications and dimensions given in this leaflet represent the state of engineering at the time of printing. Modifications may take place and materials specified may be replaced by others without prior notice.



WIKAL Alexander Wiegand GmbH & Co. KG
 Alexander-Wiegand-Straße 30
 63911 Klingenberg/Germany
 Phone (+49) 93 72/132-0
 Telefax (+49) 93 72/132-406
 E-Mail support-tronic@wika.de
 www.wika.de