



# PULSAR

## dB Transducer Series

*Short, medium  
and long range  
dB transducers*



*dB  
t  
r  
a  
n  
s  
d  
u  
c  
e  
r  
s*

Innovative design has led to the dB range of transducers being quite unlike anything seen in ultrasonic level measurement before.

Previously, there were high-voltage, frequency-dependent transducers, susceptible to electrical noise and requiring special, protected interconnection cables, or weak low-voltage transducers designed with flammable atmosphere approval and not application performance in mind.

Pulsar engineers have re-written the rules! The new innovative design utilizes a state-of-the-art circuit board and transformer built into each transducer. Here's how it works:

The electronics provide 24Vdc to the transducer. This is transformed into a 3,000 volt Peak-to-Peak echo pulse. The received pulse is then converted into a "current signal" that is processed in the electronics by our ATEM algorithms. Our transducers are completely unaffected by electrical noise because we do not use a "mV signal".



The range of dB transducers have, as standard:

- High resolution & Narrow beam angles
- Intrinsically safe (EEx ia) for zone 0
- Fm approved - Class I, DIV I, Grp A, B, C, & D
- Integral temperature compensation
- Small and light-weight
- Short blanking distances
- Robust, Nema 6P (IP68) construction

### **dB3**

#### **Short range level measurement**

Range: .4 to 9.8 ft (0.15m to 3m)

Nominal operating frequency:  
125kHz

PZT ceramic transducer element

Housing: 3.38 inch diameter

Beam angle: 12° @-3 dB

Effective Beam Angle: 3°



### **dB6**

#### **Short range level measurement**

Range: 1 to 19.7 ft (0.3m to 6m)

Nominal operating frequency: 50kHz

PZT ceramic transducer element

Housing: 3.38 inch diameter

Beam angle: 10° @-3 dB

Effective Beam Angle: 3°

### **dB10**

#### **Medium range level measurement**

Range: 1 to 32.8 ft (0.3m to 10m)

Nominal operating frequency: 50kHz

PZT ceramic transducer element

Housing: 3.38 inch diameter

Beam angle of 10° @-3 dB

Effective Beam Angle: 3°

### **dB15**

#### **Long range level measurement**

Range: 1.5 to 49.2 ft (0.4m to 15m)

Nominal operating frequency: 41kHz

Piezoflex™ homopolymer transducer element

Housing: 3.38 inch diameter

Beam angle of 5° @-3 dB

Effective Beam Angle: 3°

### **dB25**

#### **Long range level measurement**

Range: 1.5 to 82 ft (0.4m to 25m)

Nominal operating frequency: 30kHz

Piezoflex™ homopolymer transducer element

Housing: 6.69 inch diameter

Beam angle of 5° @-3 dB

Effective Beam Angle: 3°

### **dB40**

#### **Long range level measurement**

Range: 2 to 132 ft (0.7m to 40m)

Nominal operating frequency: 20kHz

Piezoflex™ homopolymer transducer element

Housing: 9 inch diameter

Beam angle of 5° @-3 dB

Effective Beam Angle: 3°

**PULSAR, Inc.**

P.O. Box 799

Shalimar, FL 32579

Telephone:

(850) 609-1777

Fax:

(850) 651-4777

E-mail:

info@pulsar-us.com

Web site:

<http://www.pulsar-us.com>

*Specifying information and wiring diagrams are available on request from Pulsar*

# Technical Specification: dB Transducers

## Data Applicable to all transducers

<b>Operating Temperature Range</b>	(-40°C to +90°C) -40°F to +194°F
<b>Hazardous Area Approval</b>	FM approved, Class I, Div I, Grp A, B, C, D - Class II, Div I, Grp E, F, G Standard EEx m IIC T6 or optional EEx ia IIC T6
<b>Ingress Protection Rating</b>	(IP68 to BS EN 60068-2-17 : 1995 & BS EN 60529) Nema 6P
<b>Integral cable length</b>	optional - any custom length, 5 or 10 meters
<b>CE Approvals</b>	EMC tested to BS EN 50081-1 : 1992 for emissions and BS EN50082-2 : 1995 for immunity Electrical safety tested to BS EN 61010-1 : 1993
<b>Bump, Shock &amp; Vibration</b>	To BS EN 60068-2-29, BS EN 60068-2-27 & BS EN 60068-2-6

## Housing Details

	Housing Material	Housing dia. inch (mm)	Housing ht. inch (mm)	Mounting Connection
<b>dB3</b>	Valox 357	3.38 (86)	3.86 (98)	1" NPT or BSP
<b>dB6</b>	Valox 357	3.38 (86)	4.17 (106)	1" NPT or BSP
<b>dB10</b>	Valox 357	3.38 (86)	4.17 (106)	1" NPT or BSP
<b>dB15</b>	Valox 357	3.38 (86)	4.72 (120)	1" NPT or BSP
<b>dB25</b>	Valox 357	6.69 (170)	4.72 (120)	1.5" NPT or BSP

## Optional Flanges All have PTFE (Teflon) full face on process side.

Flanges	ANSI	2"	3"	4"	6"	8"
<b>dB3</b>		✓	✓			
<b>dB6</b>			✓	✓	✓	
<b>dB10</b>			✓	✓	✓	
<b>dB15</b>			✓	✓	✓	
<b>dB25</b>					✓	

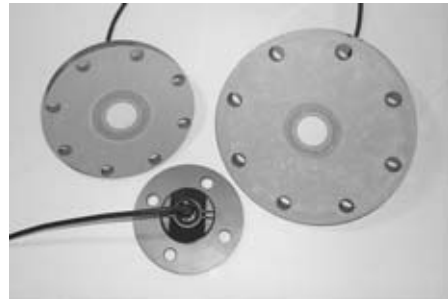

## Options

<b>Blind Flanges</b>	CPVC with 1" NPT 4,6,8, & 10 inch sizes
<b>Facings: Foam</b>	Closed Cell Soft Foam for increased power in dry dusty environments
<b>Teflon (Standard on all Flanged Transducers)</b>	PTFE for chemical compatibility
<b>Submergence Shield</b>	For continuous operation in applications at risk of submergence
<b>Aiming Kit</b>	For easy transducer aiming in solids applications (drawing available on request)

## Aiming Kit

We recommend the installation of an aiming kit when measuring solids material. This kit allows the transducer to be aimed towards the discharge point at the bottom of the silo or tank. We recommend the location to be 1/4 the radius from the outside wall towards the center and as far away as possible from the fill point, dust collectors, ladders, vents, or any potential obstructions. It should be aimed to coincide with the materials angle of repose, enabling a more powerful signal return to the transducer.

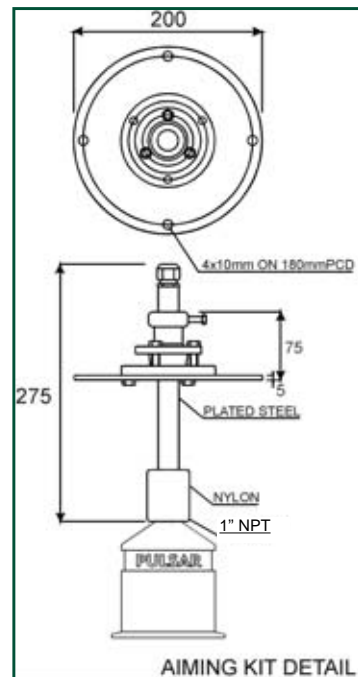

Our policy is one of constant development and improvement. Pulsar reserves the right to amend details as necessary.

Represented by