



Echotel® Model 961/962 Ultrasonic Level Switches

DESCRIPTION

Increasing demands for compliance with safety systems and overflow protection has mandated more reliable point level measurement. Echotel® Models 961 & 962 Ultrasonic Level Switches meet these demands with advanced transducer designs, extensive hazardous location approvals, and a new self-test technology.

Model 961 offers the ultimate solution to reliable single point liquid level measurement. This advanced switch uses pulsed signal technology for superior performance in difficult process conditions, and to provide excellent immunity from sources of electrical noise interference. Extensive self-testing of the electronics and transducer make this advanced switch suitable for use in Safety Integrity Level (SIL) 2 loops.

Model 962 is a dual point switch that can be used as a level controller, or to control pumps in an auto fill or auto empty mode. The tip sensitive lower gap performs well in aerated or foamy liquids, and can measure to within ¼" of the vessel bottom. The rigidity of the unique flow-through upper gap allows separations of up to 125" (318 cm) between the upper and lower transducer gaps.

FEATURES

- Single or dual point liquid level measurement
- Patent pending technology provides unsurpassed reliability and testing of electronics, transducer, piezoelectric crystals, and electromagnetic noise
- Adjustable time delay for turbulent aerated liquids
- Relay output or mA current shift with separate malfunction indication
- Integral or remote mount electronics
- Pulsed signal technology
- Extensive FM, CSA, and ATEX explosion proof and intrinsically safe approvals
- Suitable for Safety Integrity Level (SIL) 2 loops



Model 961



Model 962

APPLICATIONS

- High level alarm
- Low level alarm
- Overflow protection
- Pump protection
- Seal pot level
- Pump control

INDUSTRIES

- Chemical
- Petrochemical
- Pulp and paper
- Food and pharmaceutical
- Power
- Water and wastewater

TECHNOLOGY

BASIC OPERATION

Model 961/962 switches utilize ultrasonic energy to detect the presence or absence of liquid in a single or dual point transducer. Ultrasonic contact level technology uses high-frequency sound waves that are easily transmitted across a transducer gap in the presence of a liquid media, but are attenuated when the gap is dry. Model 961/962 switches use an ultrasonic frequency of 2 MHz to perform this liquid level measurement in a wide variety of process media and application conditions.

The transducer uses a pair of piezoelectric crystals that are encapsulated in epoxy at the tip of the transducer. The crystals are made of a ceramic material that vibrates at a given frequency when subjected to an applied voltage. The transmit crystal converts the applied voltage from the electronics into an ultrasonic signal. When liquid is present in the gap, the receive crystal senses the ultrasonic signal from the transmit crystal and converts it back to an electrical signal. This signal is sent to the electronics to indicate the presence of liquid in the transducer gap. When there is no liquid present, the ultrasonic signal is attenuated and is not detected by the receive crystal.

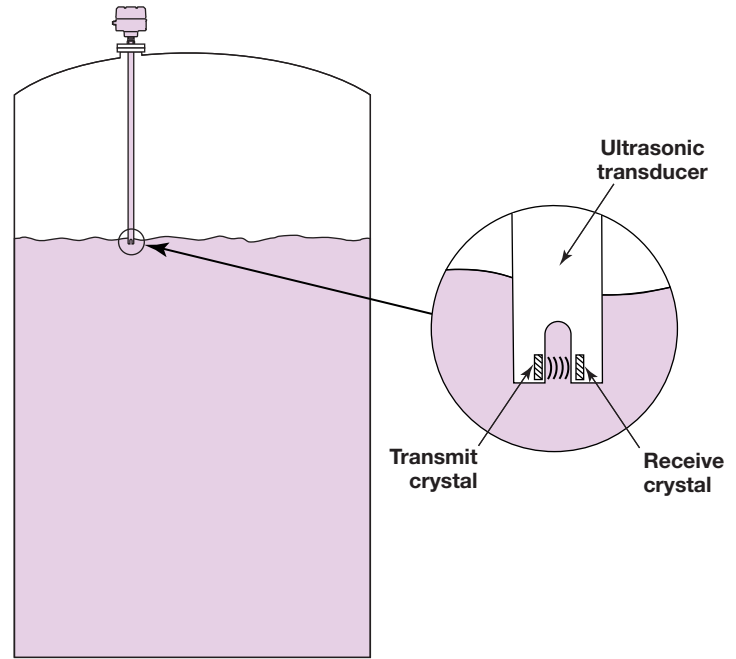

Ultrasonic signal transmission across transducer gap

PULSED SIGNAL TECHNOLOGY



Challenging process conditions such as aeration, suspended solids, and high viscosities are easily handled with the pulsed signal technology utilized in the 961/962 switches. Pulsed signal circuitry drives the transmit piezoelectric crystal to produce powerful pulses of high-frequency ultrasonic energy. These ultrasonic pulses are readily transmitted through liquids, but are attenuated when the transducer

gap is dry. This technology also provides excellent immunity from electromagnetic noise interference.

Pulsed signal technology makes the 961/962 units more reliable than older continuous wave ultrasonic switches. Unlike many tuning forks, pulsed signal ultrasonic switches do not need to be configured for different media densities, making these units the most universally applied level switches on the market today.

SAFETY INTEGRITY LEVEL (SIL)

Critical process control applications demand reliable instruments that provide high levels of safety. The introduction of standards such as IEC 61508, IEC 61511 and ISA 84, have generated interest in using Safety Instrumented Systems (SIS) as a means to define the reliability of instruments in a control loop. All

versions of the Model 961/962 switches undergo a detailed performance evaluation called a Failure Modes, Effects and Diagnostics Analysis (FMEDA). Three key components of the FMEDA are the Safety Integrity Level (SIL), Safe Failure Fraction (SFF) and the average Probability of Failure on Demand (PFDavg).



	961 Relay	961 Current Shift	962 Relay	962 Current Shift
SIL	2 as 1001	2 as 1001	2 as 1001	2 as 1001
SFF	92.0%	91.4%	91.5%	91.8%
PFDavg	1.77E-04	1.61E-04	2.31E-04	1.87E-04

ADVANCED SELF-TEST AND DIAGNOSTICS

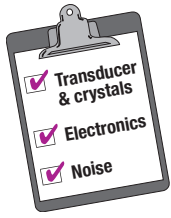

Ultrasonic switches are often used as the last means of detecting whether a process vessel will overflow and cause a spill of potentially hazardous liquids, or empty out and possibly cavitate the pumps. In these critical applications it is desirable to have a method of periodically testing the ultrasonic switch to ensure that it is functioning properly.

Model 961/962 switches feature an advanced patent pending technology that not only tests the electronics, transducer, and piezoelectric crystals, but also tests for the presence of industrial sources of environmental noise. Should the switch detect any problems a malfunction output is generated to alarm the user, and a red LED is lit to indicate an alarm condition.

Self-test is performed automatically and continuously several times per second to verify proper operation of 961/962 switches. In addition, a pushbutton is provided to initiate a manual self-test mode. Pressing this test button stops all transmit pulses, which simulates an electronics failure. This failure is reported as:

- 3.6 or 22 mA (selectable) with current shift output units
- SPDT malfunction relay de-energizes with relay output units

Taking diagnostics one step further is the unique noise self-test mode feature that is standard in all 961/962 switches. This tests for electromagnetic and acoustical noise that can influence many instrumentation technologies. If high levels of environmental noise are detected, the electronics reports a fault condition to alert the user of potential instrumentation reliability concerns.

A microprocessor in the 961/962 electronics continuously monitors all self-test data. Should a fault occur, the microprocessor can determine whether the malfunction is due to the electronics, transducer, piezoelectric crystals, or the presence of environmental noise. A pushbutton and Fault LED is used to assist in troubleshooting the switch:

- ✱ One flash of the Fault LED indicates a problem with the transducer or piezoelectric crystals
- ✱✱ Two flashes of the Fault LED indicates a problem with one of the electronics boards
- ✱✱✱ Three flashes of the Fault LED indicates excessive levels of environmental noise

ADJUSTABLE TIME DELAY



Turbulence and splashing can cause some fixed time response switches to produce false level alarms. Model 961/962 switches overcome this difficulty with an adjustable time delay feature.

A potentiometer allows a ½ to 45 second delay to be set to disregard waves or splashes, and reliably detect the true liquid level.

RELIABLE TRANSDUCER DESIGN



Dependable point level measurement begins with reliable sensor technology. Over 25 years of ultrasonic level switch technology is behind the Model 961/962 single and dual gap transducers. The result is a new patent pending transducer design that offers superior performance in difficult process conditions.

Model 961 has a tip-sensitive transducer with an arched gap for superior performance in aerated or foamy liquids. Dual point Model 962 features a tip sensitive lower gap and flow through upper gap. This robust design allows separations of 125 inches (318 cm) between the upper and lower transducer gaps.

APPLICATIONS

TYPICAL

Model 961 single point switches may be used for high or low level alarm, as well as for pump protection. The Model 962 dual point unit is typically configured to measure high/low, high/high, or low/low levels.

The single point 961 can be mounted vertically or horizontally in vessels, bridles, or pipes. The dual gap 962 is always top mounted.

A broad selection of transducer materials allow the 961/962 to be used in a wide variety of process media. Metallic transducers include 316 SS, Hastelloy® C, and Monel®. The 316 SS transducer has a NACE construction option for sour gas service, and can also be built per ASME B31.1 and B31.3 piping codes. Thermoplastic transducers include Kynar® and CPVC. These corrosion resistant plastic transducers feature a stiffening tube that runs the length of the transducer for extra rigidity. Kynar-faced 316 SS flange options are offered with the Kynar transducers.

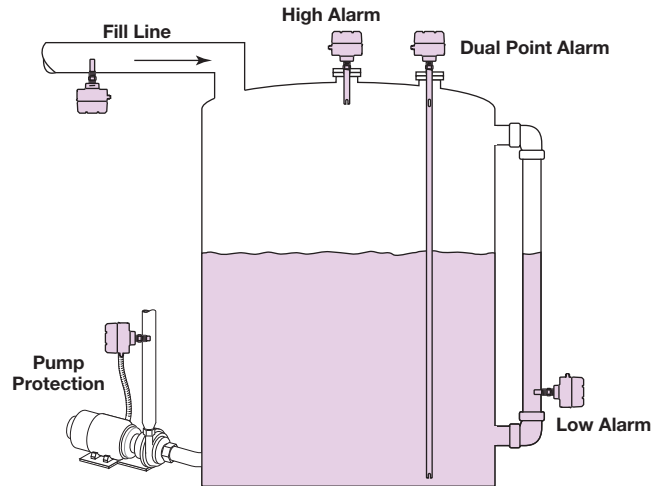

PUMP CONTROL

A DIP switch on the Model 962 allows it to be configured to control level, or to function as a pump controller. In the pump control mode the unit can perform auto fill or auto empty of tanks, sumps, or wet wells. The tip sensitive lower gap allows liquid levels to be pumped down to within 1/4" from the bottom of the vessel. The rigidity of the flow through upper gap allows the 962 to be used even when sumps experience severe turbulence from vessel fill lines.

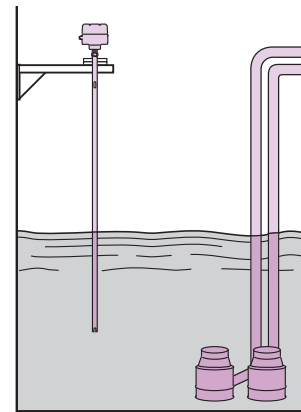

SANITARY

The sanitary version of the Model 961 features a deep drawn stainless steel housing. Tri-Clamp® and DN65 Varivent sanitary process connections are offered for use in food & beverage, pharmaceutical, and biotechnology applications. These sanitary transducers have 3-A (Authorization #596), EHEDG certification (per TNO Report # V4772/01) and a 20 Ra finish to provide a uniform and ultra-smooth surface that inhibits microbial growth. Electron beam welding technology is utilized to facilitate a crevice-free surface inside the transducer tip. This allows these transducers to be used in a wide variety of sanitary applications where CIP (Clean-in-Place) is used to remove any contamination from the transducer surface.



ELECTRONICS SPECIFICATIONS

MODEL 961/962 WITH RELAY OUTPUT

Supply Voltage	18 to 32 VDC, or 102 to 265 VAC, 50/60 Hz	
Relay Outputs	961:	One DPDT level relay and one SPDT malfunction relay
	962:	Two SPDT level relays and one SPDT malfunction relay
Relay Ratings	DPDT:	5 amps @ 120 VAC, 250 VAC, and 30 VDC, 0.4 amp @ 110 VDC
	SPDT:	5 amps @ 120 VAC, 250 VAC, and 30 VDC, 0.15 amp @ 125 VDC
Fail-safe	Selectable for high or low level	
Power Consumption	961/962:	Less than 3 watts
Ambient Temperature	-40° to +160° F (-40° to +71° C)	

MODEL 961/962 WITH CURRENT SHIFT OUTPUT

Supply Voltage	11 to 35 VDC	
Current Shift Output	961:	8 mA normal operation, 16 mA level alarm (± 1 mA)
	962:	8 mA normal operation, 12 mA lower gap alarm, 16 mA upper gap alarm (± 1 mA)
	961/962:	3.6 mA or 22 mA selectable fault signal (± 1 mA)
Loop Resistance	104 ohms with 11 VDC input, 1100 ohms with 35 VDC input	
Fail-safe	Selectable for high or low level	
Power Consumption	961/962	Less than 1 watt
Ambient Temperature	-40° to +160° F (-40° to +70° C)	

TRANSDUCER SPECIFICATIONS

MODEL 9A1/9M1 SINGLE POINT

Transducer Material	Material Code (page 10)	Operating Temperature Range	Maximum Pressure	Actuation Length
316 Stainless Steel	A*, S, N, K	-40° to +325° F (-40° to +163° C)	2000 psi (138 bar)	1" and 2" (3 and 5 cm)
316 Stainless Steel	A*, S, N, K	-40° to +325° F (-40° to +163° C)	1500 psi (103 bar)	3" to 130" (6 to 330 cm)
Hastelloy C-276	B	-40° to +325° F (-40° to +163° C)	2000 psi (138 bar)	1" and 2" (3 and 5 cm)
Hastelloy C-276	B	-40° to +325° F (-40° to +163° C)	1500 psi (103 bar)	3" to 130" (6 to 330 cm)
Monel	C	-40° to +325° F (-40° to +163° C)	1200 psi (83 bar)	1" to 130" (3 to 330 cm)
Kynar	R	-40° to +250° F (-40° to +121° C)	see graph below	2" to 130" (5 to 330 cm)
CPVC	P	-40° to +180° F (-40° to +82° C)	see graph below	1" to 130" (3 to 330 cm)

* Material Code "A" has a Cryogenic Transducer Option for -110° to +250° F (-80° to +120° C) operating temperature range

MODEL 9A2/9M2 DUAL POINT

Transducer Material	Material Code (see page 10)	Operating Temperature Range	Maximum Pressure	Actuation Length
316 Stainless Steel	A, K	-40° to +325° F (-40° to +163° C)	1500 psi (103 bar)	5" to 130" (13 to 330 cm)
CPVC	P	-40° to +180° F (-40° to +82° C)	see graph below	5" to 130" (13 to 330 cm)

Kynar Transducer Ratings

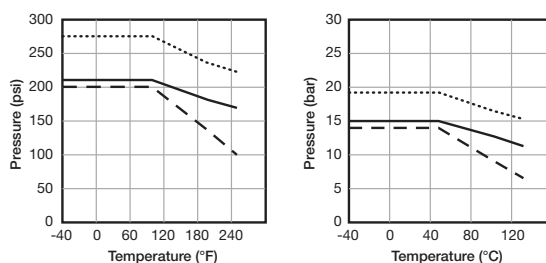

CPVC Transducer Ratings

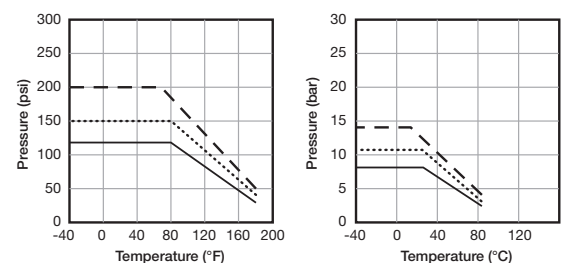

- - - Range with 1/4" NPT
 Range with 150# flange
 ——— Range with PN16 flange

PERFORMANCE SPECIFICATIONS

Repeatability	±0.078" (2 mm)	
Response Time	½ second typical	
Time Delay	Variable 0.5 – 45 seconds on rising and falling levels	
Self-Test	Automatic:	Continuously verifies operation of electronics, transducer, piezoelectric crystals, and electrical noise
	Manual:	Pushbutton verifies operation of electronics, transducer, and piezoelectric crystals
Shock Class	ANSI/ISA-S71.03 Class SA1	
Vibration Class	ANSI/ISA-S71.03 Class VC2	
Humidity	0 – 99%, non-condensing	
Electromagnetic Compatibility	Meets CE requirements EN 61326	

PHYSICAL SPECIFICATIONS

Housing Material	Cast aluminum A356-T6, cast 316 stainless steel, or deep drawn 304 stainless steel (sanitary housing)	
Cable Entry	Dual ¼" NPT, or M20 connections (one end is plugged)	
Gross Weight	961/962 Electronics:	2.2 lbs. (1.0 kg)
	2" (5 cm) Transducer:	0.6 lbs. (0.3 kg)

DIMENSIONAL SPECIFICATIONS

INCHES (mm)

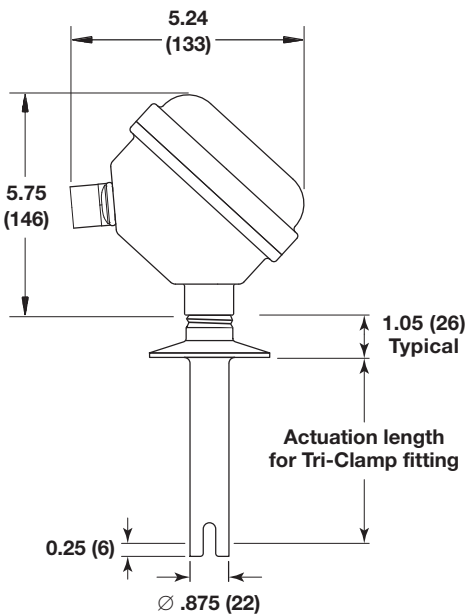

Model 961
with sanitary housing
with Tri-Clamp® 16 AMP Fitting

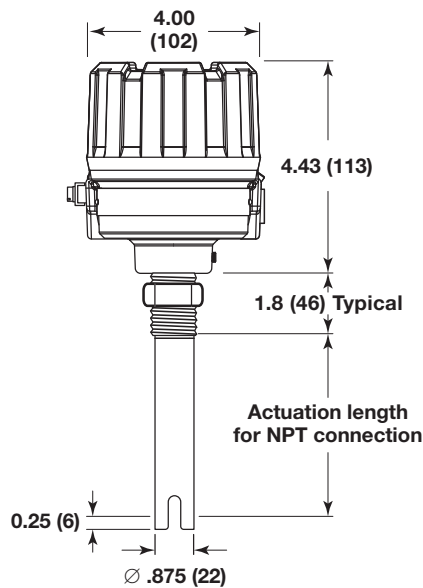

Model 961
with cast aluminum housing
with NPT Connection

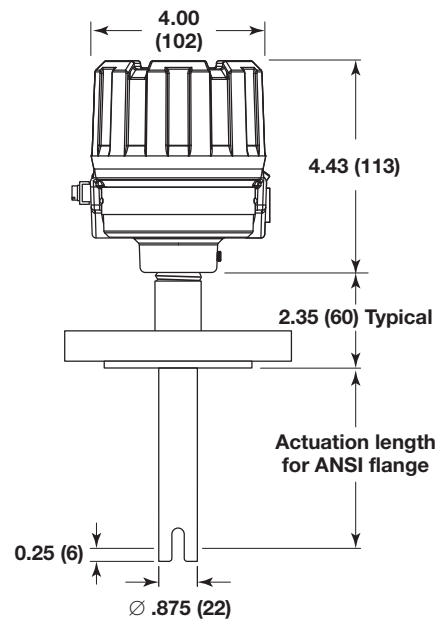

Model 961
with cast stainless steel
housing and ANSI Flange

DIMENSIONAL SPECIFICATIONS

INCHES (mm)

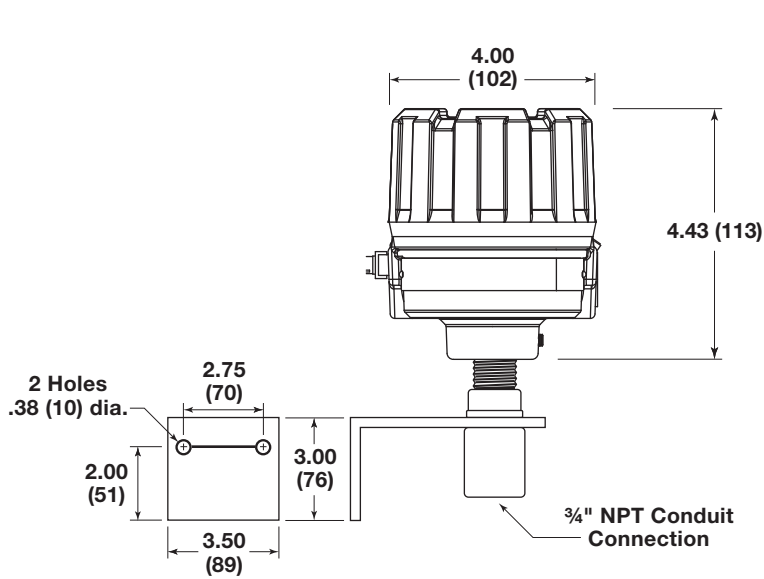

Model 961/962 with Remote Electronics

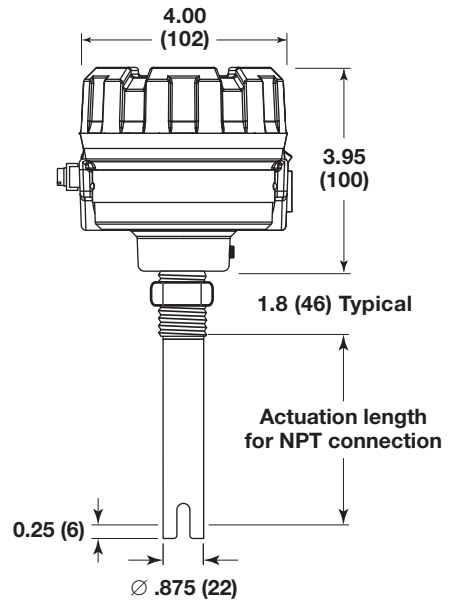

Remote Transducer with NPT Connection

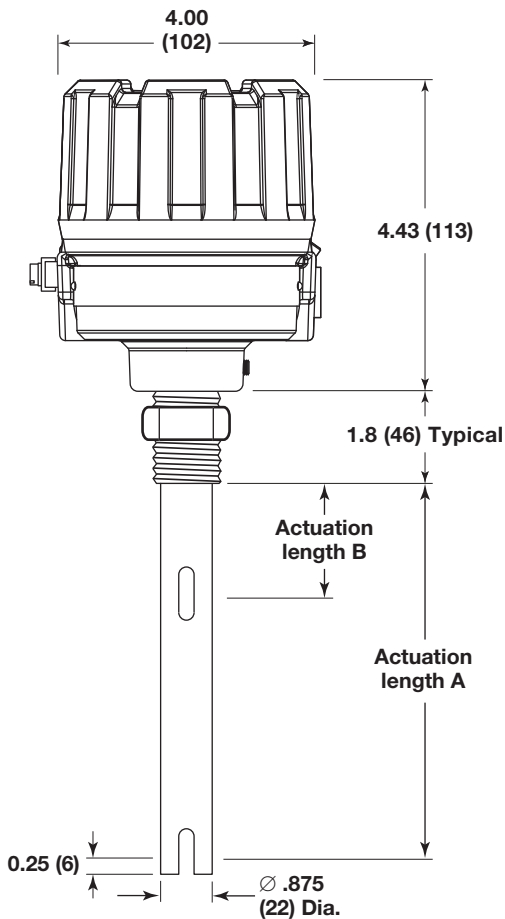

Model 962 with NPT Connection

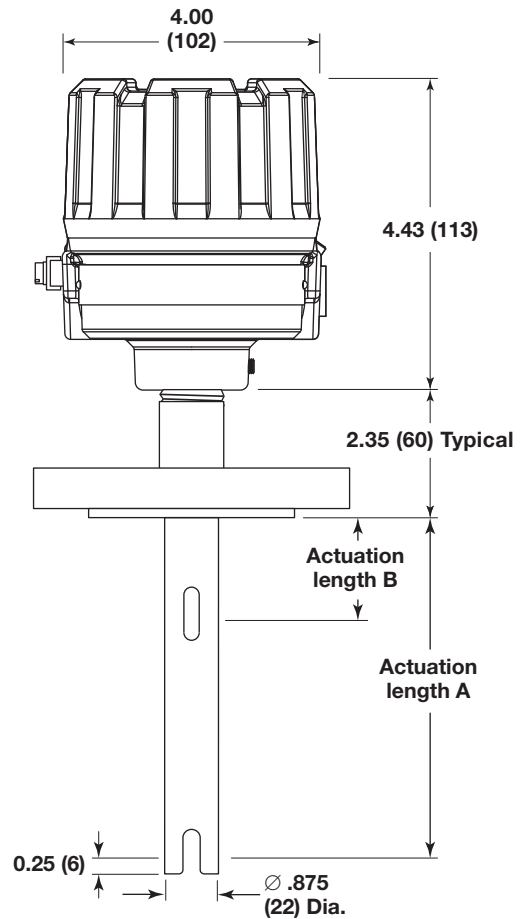

Model 962 with ANSI Flange

MODEL NUMBER

961/962 ELECTRONICS



Models available for quick shipment, usually within one week after factory receipt of a purchase order, through the Expedite Ship Plan (ESP)

BASIC MODEL NUMBER

961	Single-point electronics
962	Dual-point electronics

INPUT POWER

2	18 to 32 VDC line-powered
5	11 to 35 VDC loop-powered
7	102 to 265 VAC line-powered

OUTPUT SIGNAL

0	mA current shift (available with Input Power code 5)
D	5 amp gold flash relays (available with Input Power codes 2 or 7)

HOUSING COVER

0	Standard housing cover
1	Glass window cover (available with Electronics Housing codes 0, 1, 4 or 5)

MOUNTING

0	Integral
1	Remote (requires Connecting Cable from page 11)

AGENCY APPROVAL

1	FM/CSA Intrinsically safe , Non-Incendive & Explosion Proof * (available with Output Signal code 0)
3	FM/CSA Explosion proof & Non-Incendive (available with Output Signal code D, and housing codes 0, 1, 2 & 3)
7	FM/CSA Non-incendive (available with Output Signal codes 0 & D and Housing codes 4 & 5)
A	ATEX II 1G EEx ia II C T5, Intrinsically safe (available with Output Signal code 0)
C	ATEX II 1/2G EEx d II C T6, Explosion proof (available with Output Signal code 0 or D)
E	ATEX EEx n II T6 Non-sparking (available with Output Signal codes 0 & D and Housing codes 4 & 5)

* Explosion Proof approvals not available with housing codes 4 & 5

ELECTRONICS HOUSING

0	Cast aluminum with 3/8" NPT dual conduit entries
1	Cast aluminum with M20 dual conduit entries
2	Cast SS with 3/8" NPT dual conduit entries
3	Cast SS with M20 dual conduit entries
4	Deep drawn SS with 1/2" NPT dual conduit entries
5	Deep drawn SS with M20 dual conduit entries

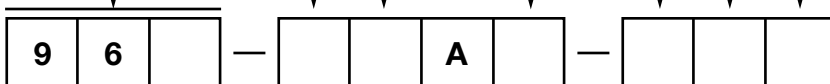

MODEL NUMBER

9 6 1 SINGLE POINT TRANSDUCER

Models available for quick shipment, usually within one week after factory receipt of a purchase order, through the Expedite Ship Plan (ESP)

TRANSDUCER UNIT OF LENGTH

A	English (length in inches)
M	Metric (length in centimeters)

MATERIALS OF CONSTRUCTION

A	316/316L stainless steel
S	316/316L with 20 Ra sanitary finish (use only with Process Connection codes 3T, 4T, or VV)
B	Hastelloy C-276
C	Monel
R	Kynar* (use only with Process Connection codes 11, 23, 33, 43, BA, CA, DA)
P	CPVC (use only with Process Connection codes 11, 23, 33, 43, BA, CA, DA)
N	316/316L stainless steel, NACE construction
K	316/316L stainless steel, ASME B31.1 & B31.3 construction

* Flanged transducers have Kynar faced 316 stainless steel flanges

PROCESS CONNECTIONS

THREADED CONNECTIONS

11	¾" NPT
21	1" NPT
22	1" BSP (G1)

SANITARY CONNECTIONS

3T	1"/1½" Tri-Clamp® 16 AMP fitting
4T	2" Tri-Clamp® 16 AMP fitting
VV	DN65 – Varivent®

ANSI RAISED FACE FLANGES

23	1" 150# ANSI RF flange
24	1" 300# ANSI RF flange
25	1" 600# ANSI RF flange
33	1½" 150# ANSI RF flange
34	1½" 300# ANSI RF flange
35	1½" 600# ANSI RF flange
43	2" 150# ANSI RF flange
44	2" 300# ANSI RF flange
45	2" 600# ANSI RF flange

EN/DIN FLANGES

BA	DN 25 PN 16 EN 1092-1 Type A
BB	DN 25 PN 25/40 EN 1092-1 Type A
BC	DN 25 PN 63/100 EN 1092-1 Type B2
CA	DN 40 PN 16 EN 1092-1 Type A
CB	DN 40 PN 25/40 EN 1092-1 Type A
CC	DN 40 PN 63/100 EN 1092-1 Type B2
DA	DN 50 PN 16 EN 1092-1 Type A
DB	DN 50 PN 25/40 EN 1092-1 Type A
DD	DN 50 PN 63 EN 1092-1 Type B2
DE	DN 50 PN 100 EN 1092-1 Type B2

TRANSDUCER OPTIONS

A	Standard design
C	Cryogenic design to -110° F (-80° C) (available with Materials code A)

ACTUATION LENGTH (unit of length specified in second digit)

1" to 130" in 1" increments (Example: 4 inches = 004) 1" minimum for NPT process connections 2" minimum for BSP, sanitary, and flanged process connections 2" minimum for all Kynar transducers
Available English ESP lengths: 1", 2", 4", 6", 8", 12"
3 cm to 330 cm in 1 cm increments (Example: 6 centimeters = 006) 3 cm minimum for NPT process connections 5 cm minimum for BSP, sanitary, and flanged process connections 5 cm minimum for all Kynar transducers
Available metric ESP lengths: 3, 5, 10, 30 cm

9		1
---	--	---

--	--	--	--

--	--	--

MODEL NUMBER

CONNECTING CABLE

ELECTRONICS MODEL



6	Remote cable for Model 961
7	Remote cable for Model 962

CONNECTING CABLE LENGTH (FEET)

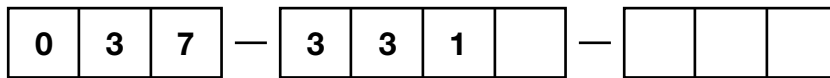
Maximum Length: 150 feet Minimum Length: 10 feet
 Example: 12 feet = **012**



AGENCY APPROVALS

AGENCY	APPROVED MODELS	PROTECTION METHOD	AREA CLASSIFICATION
FM & CSA  	96X-X0A0-X10 96X-X0A0-X11 96X-X0A0-X12 96X-X0A0-X13 96X-X0A1-X10 96X-X0A1-X11 96X-XDA0-X30 96X-XDA0-X31 96X-XDA0-X32 96X-XDA0-X33 96X-XDA1-X30 96X-XDA1-X31 with transducers 9AX-XXXX-XXX or 9MX-XXXX-XXX	Explosion Proof	Class I, Div. 1, Groups B,C, & D Class II, Div. 1, Groups E,F, & G Class III, Type 4X, IP 66, T6
	96X-XXAX-XXX or with transducers 9AX-XXXX-XXX or 9MX-XXXX-XXX	Non-Incendive	Class I, Div. 2, Groups A,B,C, & D Class II, Div. 2, Groups E,F, & G Class III, Type 4X, IP 66, T4
	96X-50A0-X1X with transducers 9AX-XXXX-XXX or 9MX-XXXX-XXX	Intrinsically Safe	Class I, Div. 1, Groups A,B,C, & D Class II, Div. 1, Groups E,F, & G Class III, Type 4X, IP 66, T4
ATEX 	96X-XXAX-XC0 96X-XXAX-XC1 96X-XXAX-XC2 96X-XXAX-XC3 with transducers 9XX-AXXA-XXX 9XX-SXXA-XXX 9XX-BXXA-XXX 9XX-CXXA-XXX 9XX-NXXA-XXX 9XX-KXXA-XXX	Explosion Proof	Ex II 1/2 G, EEx d IIC T6
	96X-50AX-XAX with transducers 9XX-AXXA-XXX 9XX-SXXA-XXX 9XX-BXXA-XXX 9XX-CXXA-XXX 9XX-NXXA-XXX 9XX-KXXA-XXX	Intrinsically Safe	Ex II 1 G, EEx ia IIC T5



These units are in compliance with:

1. The EMC Directive: 89/336/EEC. The units have been tested to EN 61326.
2. Directive 94/9/EC for equipment or protective system for use in potentially explosive atmospheres.

QUALITY



The quality assurance system in place at Magnetrol guarantees the highest level of quality throughout the company. Magnetrol is committed to providing full customer satisfaction both in quality products and quality service.

Magnetrol's quality assurance system is registered to ISO 9001 affirming its commitment to known international quality standards providing the strongest assurance of product and service quality available.

ESP

Expedite Ship Plan

Several Echotel Model 961 units are available for quick shipment, usually within one week after factory receipt of a purchase order, through the Expedite Ship Plan (ESP).

To take advantage of ESP, simply match the color coded model number codes (standard dimensions apply).

ESP service may not apply to orders of ten units or more. Contact your local representative for lead times on larger volume orders, as well as other products and options.

WARRANTY



All Magnetrol electronic level and flow controls are warranted free of defects in materials or workmanship for one full year from the date of original factory shipment.

If returned within the warranty period; and, upon factory inspection of the control, the cause of the claim is determined to be covered under the warranty; then, Magnetrol will repair or replace the control at no

cost to the purchaser (or owner) other than transportation.

Magnetrol shall not be liable for misapplication, labor claims, direct or consequential damage or expense arising from the installation or use of equipment. There are no other warranties expressed or implied, except special written warranties covering some Magnetrol products.

For additional information, see Instruction Manual 51-646.



5300 Belmont Road • Downers Grove, Illinois 60515-4499 • 630-969-4000 • Fax 630-969-9489 • www.magnetrol.com
145 Jardin Drive, Units 1 & 2 • Concord, Ontario Canada L4K 1X7 • 905-738-9600 • Fax 905-738-1306
Heikensstraat 6 • B 9240 Zele, Belgium • 052 45.11.11 • Fax 052 45.09.93
Regent Business Ctr., Jubilee Rd. • Burgess Hill, Sussex RH15 9TL U.K. • 01444-871313 • Fax 01444-871317

Copyright © 2007 Magnetrol International, Incorporated. All rights reserved. Printed in the USA.
Performance specifications are effective with date of issue and are subject to change without notice.

Magnetrol & Magnetrol logotype and Echotel are registered trademarks of Magnetrol International
Kynar® is a registered trademark of Elf Atochem North America, Inc.
Hastelloy® is a registered trademark of HAYNES INTERNATIONAL, INC. (DELAWARE CORPORATION).
Monel® is a registered trademark of the INCO family of companies.
Tri-Clamp® is a registered trademark of Ladish Co.
Varivent® is a registered trademark of Tuchenhagen GmbH LTD

BULLETIN: 51-137.1
EFFECTIVE: September 2007
SUPERSEDES: January 2006