

MODLINE[®]

Non contact temperature measurement

Features

Rugged, compact, and self-contained - the Modline 4 is designed and built for long, trouble free service in harsh environments and is packaged in a sealed, cast aluminum NEMA 4 rated housing.

Stable drift-free operation

The Modline 4 DC operation has no moving parts - which guarantees a stable performance. The solid state electronics incorporates a chopper-stabilized amplifier which assures long term, accurate drift-free operation and the 4-20 mA high level current output assures reliable signal transmission over long lines.

Two-wire transmitter is versatile, easy to install

The Modline 4 requires two wires, a power supply (range of 16 to 40 Vdc) and an installed compatible output (recording or control instrument) to complete the instrument system loop.

The two-wire operation simplifies the installation, operation and maintenance of the infrared thermometer. Screw terminals allow easy and secure wire hook ups. The digital emissivity control allows adjustments in 0.01 increments and a response time adjustment pot (potentiometer) lets you select values from 0.15 to 10 seconds to match any process requirements.



The loop voltage is provided by the power supply. The loop current is determined by the Modline 4 instrument ordered, and is calibrated to provide a linear output of 4 to 20 mA. Instruments within the current loop are supplied with a current proportional to the temperature span of the transmitter (20 mA at full scale and 4 mA at zero scale).

A number of instruments can be placed within the series current loop - providing that the total voltage drop for each instrument does not exceed the total loop voltage. There are six different spectral responses for a wide variety of application processes

and the Modline 4 flanges makes it easy to mount accessories for hostile environments.

Specifications

Accuracy

Within 0.75% of full scale temperature or 3°F (1.7°C), whichever is greater. *For the 22 series:* within 1.0% full scale or 5°F (2.8°C), whichever is greater. *For the 43 series:* ambient temperature transients of 20°F (10°C) will cause some errors in reading until sensor is stabilized - allow 15 minutes for warm-up.

Modline 4

Repeatability

0.3% of full scale temperature. *For the 22 series:* 0.5% full scale

Response Time

(to 95% of any change in input)
Continuously adjustable from approximately 0.15 to 10 seconds. *For the 43 series:* set to 10 seconds for temperatures from 300°F (150°C) or lower.

Emissivity Range

Adjustable from 0.10 to 0.99 in 0.01 increments. *For the 43 series:* minimum emissivity setting is 0.9 for all temperatures 300°F (150°C) or lower and 0.5 for temperatures above 300°F (150°C).

Peak Picker Option

Decay rate adjustable from 15 seconds to 30 minutes (approximately) for full scale decay. *Note: Peak picker is a standard feature for 22 series instruments.*

Power Supply / Load Requirements

Input voltage: 24 Vdc nominal
Input voltage range: 16 Vdc minimum to 40 Vdc maximum
Max. load resistance:
≤ 1 ohm at 16 Vdc; 400 ohms at 24 Vdc; 1200 ohms at 40 Vdc

Output Current

4 to 20 mAdc

Temperature Co-efficient

≤ 0.015% of span per °F change from nominal value of 77°F over a range of 32 to 150°F; ≤ 0.027 of span per °C change from nominal value of 25°C over a range of 0 to 66°C. *For the 43 series:* ≤ 0.05% of span per °F change from nominal value of 77°F over range of 32 to 150°F; ≤ 0.09% of span per °C change from nominal value of 25°C over range of 0 to 66°C.

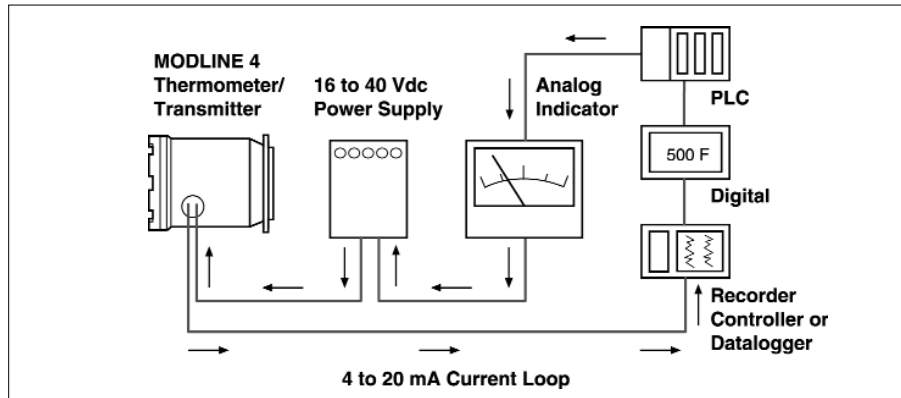

Modline 4 two-wire transmitter diagram

For the 22 series: ≤ 0.020% of span per °F change from nominal value of 77°F over range of 32 to 130°F; ≤ 0.035% of span per °C change from nominal value of 25°C over range of 0 to 55°C.

Ambient Temperature Range

32 to 150°F / 0 to 66°C (*without water cooling*); 32 to 400°F / 0 to 200°C (*with water cooling*). *For the 22 series:* 32 to 130°F / 0 to 55°C (*without water cooling*).

Sensor Humidity

Limited from 10 to 90% non-condensing (distance)

Environmentally-sealed Housing

Aluminum casting rated NEMA 4, IP56

Optical/Mechanical Alignment

Optical axis is within one degree of mechanical centerline (within 0.2 inches per foot separation distance / 17 mm per meter separation distance). *For the 22 series:* optical axis is within two degrees of mechanical centerline (within 0.4 inches per foot / 33mm per meter) separation distance.

Sensing Head Weight

2.6 lbs / 1.2 kg; 20 lbs / 9.25 kg (*with optional water cooling enclosure*).

Accessories

Power Supply

The Ircan 24 VDC power supply is capable of powering up to ten Modline 4 units. The rugged, sealed package can be chassis-mounted or back panel mounted using 4 tapped holes (factory provided). The screw terminals permit secure wiring. A current-limiting circuit protects the power supply in case of a short circuit. Model No. PS-4-0/1 specifications:

Output voltage: 24 V, ±1%

Output current: 350 mA

Ambient temperature range: -20 to 70°C

I/O isolation voltage: 1500V RMS

Resistance: 100 meg ohms

Power: 115/240 V, 50/60 Hz



Power supply

Modline 4

Temp View Meter (TV-View VAAC)

The Temp View digital indicator is powered by 110 or 220 Vac power. The display is programmable to work with Modline 4 sensors in both degree F and degree C. The indicator is NEMA 4 rated, IP65, with a sealed front bezel. Optional plug in cards feature a 24 V excitation voltage; a 4-20 mA linear output; and four set point alarms.



Temp View meter

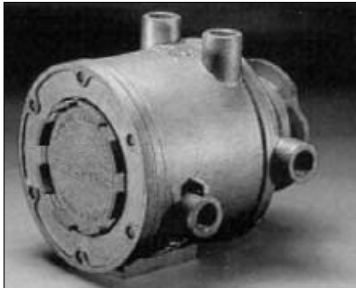

EE-2 Water-cooling enclosure

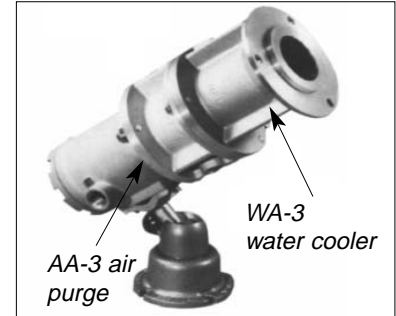

Air purge, water cooling and swivel base mounting accessories

Options

Peak Picker

The peak picker option provides circuitry which responds to the highest instantaneous temperature value and holds this signal through an adjustable slow decay rate.

The peak picker option is necessary if the sight path in your process is interrupted by smoke or steam (between the instrument and the target) or if the target moves in and out of view of the instrument.



Peak Picker

Water-Cooling Enclosure and Air Purge

Water flow of 10 to 20 gallons per hour at temperatures of 90°F / 32°C is sufficient for most applications. When the case temperature of the instrument is expected to exceed 150°F / 66°C due to ambient conditions, the WA-3 water cooling accessory gives a uniform temperature and isolates the transmitter electronics

from thermal influence and permits operation in ambient temperatures up to 180°F (85°C). The EE-2 permits operations in ambients up to 400°F / 200°C. The Ircon AA-3 air purge accessory is recommended when the environment contains smoke, particles, steam, and other impurities. A flow of clean, dry industrial air will keep the optics clear under most industrial conditions.

Swivel Mounting Base

The SB-1 swivel mounting base lets you aim the line of sight. You can tilt, swivel and lock the mounting base in place. *Note: You cannot use the WA-3 and AA-3 together with models 43-04F or 43-02C because the cone of vision is obstructed and would cause errors in reading. However, they can be used individually.*

Optical Characteristics

Spot Size vs Separation Distance

The sensor responds to infrared radiation in an area indicated by the cone of vision. It will measure the target temperature within that cone. The spot size is the diameter of the cone at a particular separation distance.

Optical Characteristics Reference

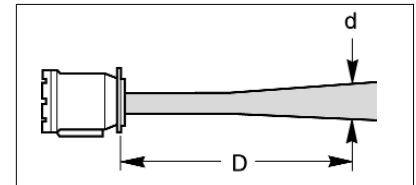

Note: above diagram not to scale

d = Spot size

D = Separation distance

Note: 43 Series available in "standard" resolution only

Spot Size vs Optical Resolution chart

STANDARD RESOLUTION			
D	d	D	d
(inches)	(inches)	(mm)	(mm)
0 to 15	1.0	0 to 380	25
20	1.7	500	41
30	3.0	700	67
50	5.6	1,000	106
70	8.2	1,500	171
100	12.0	2,000	236
150	13.0	3,000	366
200	25.0	5,000	626
300	38.0	7,000	886
500	64.0	10,000	1,280
700	90.0	15,000	1,930
1,000	123.0	20,000	2,580

Standard Resolution Formula

If D > 15 inches or 380 mm

d inches = 0.13 (D inches - 15) + 1.0

d mm = 0.13 (Dmm - 380) + 25

Example: If D = 45 inches,

d = 0.13 (45 - 15) + 1.0

= 0.13 (30) + 1.0 = 3.9 + 1.0

= 4.9 inches = 5 inches

Models 43-04F and 43-02C only:

D inches = 0.17 (D inches) + 1.0

d mm = 0.17 (Dmm) + 25

Modline 4

Spot size vs. optical resolution charts (continued)

HIGH RESOLUTION			
D (inches)	d (inches)	D (mm)	d (mm)
0.0	1.00	0	25
15.0	1.25	300	30
30.0	1.5	700	37
60.0	2.0	1,000	42
70.0	2.5	1,500	50
100.0	4.0	2,000	75
150.0	6.5	3,000	125
200.0	9.0	5,000	225
300.0	14.0	7,000	325
500.0	24.0	10,000	475
700.0	34.0	15,000	725
1,000.0	49.0	20,000	975

High Resolution Formula

If D > 60 inches or 1500 mm
 $d \text{ inches} = 0.05 (D \text{ inches} - 60) + 2.0$
 $d \text{ mm} = 0.05 (D \text{ mm} - 1500) + 50$

If D < 60 inches or 1500 mm
 $d \text{ inches} = 0.017 (D \text{ inches}) + 1.0$
 $d \text{ mm} = 0.017 (D \text{ mm}) + 25$

Example:

If D = 90 inches
 $d = 0.05 (90 - 60) + 2.0$
 $= 0.05 (30) + 2.0 = 1.5 + 2.0$
 $= 3.5 \text{ inches}$

VERY HIGH RESOLUTION			
D (inches)	d (inches)	D (mm)	d (mm)
8.0	0.3	203	7.6
15.0	1.0	381	25.4
25.0	2.0	635	50.8
35.0	3.0	889	76.2
45.0	4.0	1,143	101.6

Very High Resolution Formula

If D > 8 inches or 203 mm
 $d \text{ inches} = 0.1 (D - 8) + 0.3$
 $d \text{ mm} = 0.1 (D - 203) + 8$

Note: For sensors with water-cooled castings, multiply spot size (d) from table or formula by 1.1

Example: If "d" is 8.2 inches per table or diagram, then "d" for water-cooled casting is

$$d = 8.2 \times 1.1 = 9.02 \text{ inches}$$

Model Identification Chart

The 8-digit model number represents the specifications for a specific instrument.

Example: Model 44-05F-0-0-0-0 describes a model 44 series unit (8 to 14 microns); a temperature range of 0 to 500°F; standard optical resolution; 4 to 20 mA linear output; and a standard enclosure.

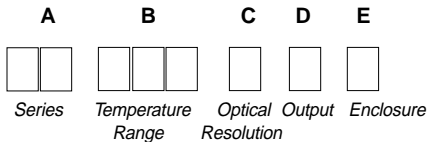

BLOCK A: Series Designation

22 = 22 series 8 - 14 μ (microns)
 43 = 43 series 3.43 μ (microns)
 44 = 44 series 8 to 14 μ (microns)
 45 = 45 series 3.7 to 4.0 μ (microns)
 46 = 46 series 2.0 to 2.6 μ (microns)
 47 = 47 series 4.8 to 5.2 μ (microns)
 48 = 48 series 7.5 to 8.5 μ (microns)

BLOCK B: Temperature Range

22 series (8 to 14 μ)
 02F = 0 to 200°F
 05F = 0 to 500°F
 10F = 0 to 1000°F
 01C = 0 to 100°C
 02C = 0 to 250°C
 06C = 0 to 600°C
 52F = -50 to 200°F
 51C = -50 to 100°C

43 series

(3.43 μ)
 04F = 120 to 400°F *
 06F = 200 to 600°F
 10F = 300 to 1000°F
 02C = 50 to 200°C *
 04C = 100 to 400°C
 05C = 150 to 500°C

44 series

(8 to 14 μ)
 02F = 0 to 200°F
 05F = 0 to 500°F
 10F = 0 to 1000°F
 01C = 0 to 100°C
 02C = 0 to 250°C
 06C = 0 to 600°C
 52F = -50 to 200°F
 51C = -50 to 100°C

45 series

(3.7 to 4.0 μ)
 15F = 500 to 1500°F
 25F = 500 to 2500°F
 08C = 300 to 800°C
 13C = 300 to 1300°C

46 series

(2.0 to 2.6 μ)
 10F = 500 to 1000°F **
 14F = 600 to 1400°F
 06C = 250 to 600°C **
 08C = 350 to 800°C

47 series

(4.8 to 5.2 μ)
 10F = 200 to 1000°F **
 15F = 500 to 1500°F
 25F = 500 to 2500°F
 06C = 100 to 600°C **
 08C = 300 to 800°C
 13C = 300 to 1300°C

48 series

(7.5 to 8.5 μ)
 06F = 0 to 600°F **
 15F = 500 to 1500°F
 25F = 500 to 2500°F
 03C = 0 to 300°C **
 08C = 300 to 800°C
 13C = 300 to 1300°C

BLOCK C Optical Resolution (1)

0 = Standard
 1 = High
 2 = Very high

BLOCK D Output

0 = 4 to 20 mAdc
 1 = 4 to 20 mAdc with peak picker
 (standard on 22 series)

BLOCK E Enclosure

0 = Standard
 1 = Water-cooled with air purge

* Minimum response time of 10 seconds for target temperature between 120 to 300°F (50 to 150°C).

Minimum emissivity of 0.9 and sensing head ambient temperature of 50 to 113°F (10 to 45°C).

** "High" resolution version may require slower response time settings.

(1) "High" resolution and "Very High" resolution not available in 22 Series or 43 series models.



ISO 9001 : 2000
 Quality System
 Certified

NIST Calibration Provider



World Headquarters

7300 N. Natchez Avenue • Niles, IL 60714 USA
 Phone: 847 967 5151 or 800 323 7660 • Fax: 847 647 0948
 Web site: www.ircon.com • E-mail: info@ircon.com

European Headquarters

Databankweg 6C • 4821 AL • Amersfoort, The Netherlands
 Phone: 31 33 450 4321 • Fax: 31 33 450 4321
 E-mail: info@ircon.nl