

MODLINE 3[®]

Infrared Temperature Measurement System

Modline 3 - the most advanced micro computer based non-contact temperature measurement system, featuring high performance, reliability and versatility.

The Modline 3 is a non-contact, infrared radiation thermometer designed to meet the critical needs of today's application requirements. Modline 3 features a broad line of infrared thermometers to match specific applications in many industries. The system offers a choice of sensors with sophisticated single lens reflex (SLR) focusing that can view spots as small as 0.012 inches (0.3mm), or sensors using two-color (ratio) technology to tolerate more than 95% reduction in radiant intensity, or fiber optic sensors for difficult to reach or obstructed targets.

The system consists of a high performance sensor and micro-computer based digital Indicator/ Processor. Many standard features are included, only a two-point On/Off controller/alarm or a PID controller are optional. Additionally, Ircon offers standard accessories to meet the demanding application requirements, such as air purge and water cooling, sight tubes and mounting assemblies.

Modline 3 utilizes advanced micro-computer technology to process temperature signals received from the sensor. This data is accurately displayed on a highly visible LED digital display in °F or °C. Programming features and control functions are viewed on a bright, highly readable Alpha Numeric, Vacuum Fluorescent display.

Standard Features

- ◆ **High Performance Sensors**
Select from 9 narrow spectral regions and temperature ranges to match specific applications
- ◆ **Micro-computer Technology**
Indicator/Processor is programmed to match specific sensor requirements and control functions using front panel buttons
- ◆ **High System Accuracy**
± 0.6% of reading ± 1 digit, or ± 0.6% of F.S. ± 1 digit, depending on model; ± 0.1% Repeatability F.S.
- ◆ **Smart Peak Picker**
With Decay rate controlled directly in degrees per second. Manual and Automatic Reset modes.



Standard Features (cont'd)

- ◆ **Track and Hold**
Hold instrument readings/outputs or allow the instrument to track real events, all via a simple contact closure from a remote switch or a relay.
- ◆ **Analog Outputs**
Select one from four available analog outputs:
0 to 20mA, 4 to 20 mA, 5µA / °F or °C and 0 to 10 Vdc
- ◆ **Remote Analog Input**
4 to 20mA signal input to the Modline 3 permits external adjustment of Emissivity/E-Slope or Controller Setpoint.
- ◆ **RS-485 Digital Interface**
Digital communication port provides a complete two-way access to Modline 3 features and functions.
- ◆ **CE Compliance**
Meets EMC directive 89/366/EEC
Meets Low Voltage directive 73/23/EEC

Optional Features

- ◆ **2- Point On/Off Control Options**
Two completely independent channels of control and/or alarming.
- ◆ **3-Mode Proportional Controller**
With a multitude of features; Auto tune, Bumpless Output Transfer, 4 to 20 mA isolated output, Internal/External Setpoint control and Hi-Lo Deviation Alarms with relay outputs.

Modline 3 Catalog

System Overview

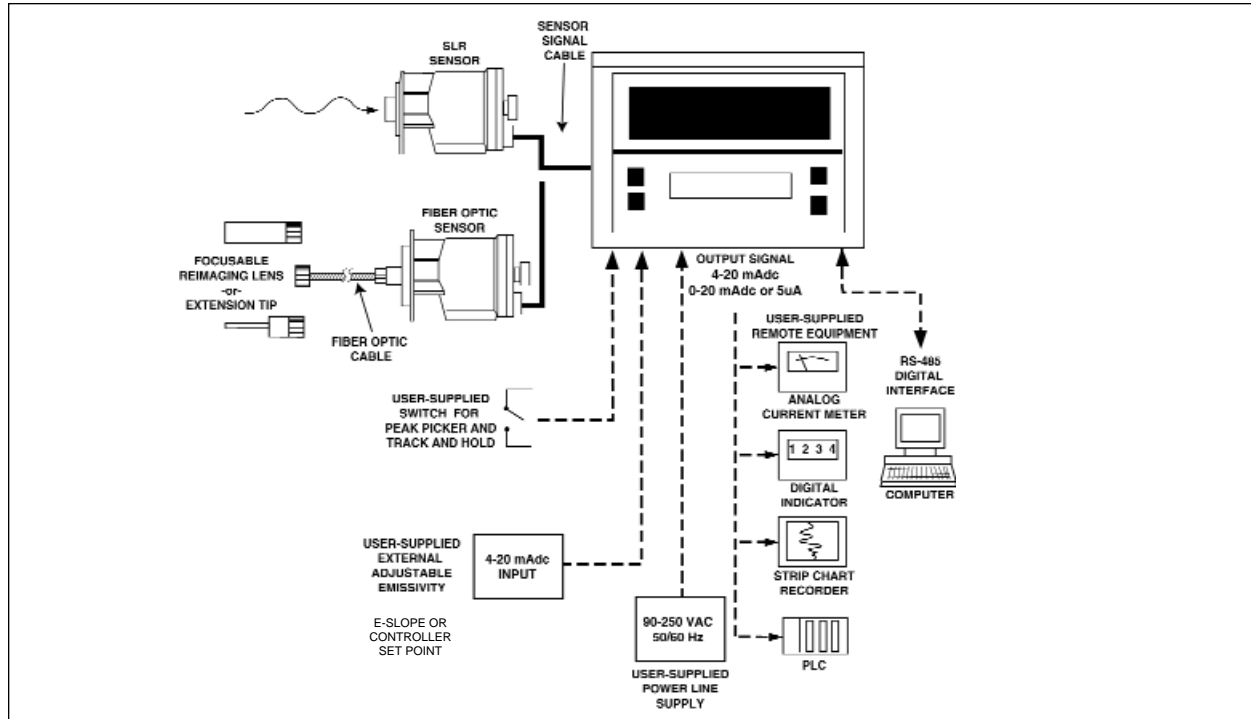

Modline 3 System Configuration for SLR and Fiber Optic Versions

Sensor Selection Chart

Series	Temp Span	Wavelength	Applications
200 200 Fiber Optic	900 - 4800°F or 500 - 2600°C 1200 - 4800°F or 650 - 2600°C	0.7 - 1.0μ 0.7 - 1.0μ	Forging, annealing, hardening, foundries, most iron and steel, incandescent processes including semiconductor processes.
340	75 - 1500°F or 25 - 800°C	3.43μ	Thin films of polyethylene, polypropylene, vinyls and nylons.
600	150 - 1400°F or 80 - 800°C	2.0 - 2.6μ	Medium temperature applications for thick plastics, rubber, textiles and metals.
700	100 - 2500°F or 50 - 2500°C	4.8 - 5.3μ	Glass surface temperature in forming, bending, tempering, annealing and sealing.
800	75 - 800°F or 25 - 400°C	7.92μ	Thin films of polyester (PET) and fluorocarbon plastics.
3G 3G Fiber Optics	500 - 2500°F or 250 - 1400°C 650 - 2500°F or 350 - 1400°C	1.5 - 1.6μ 1.5 - 1.6μ	Medium temperature applications, particularly ferrous and non-ferrous metals.
3L	500 - 1800°F or 250 - 1000°C	1.00 - 1.20μ or 1.5 - 1.6μ, and 1.65 - 1.71μ	Low temperature non-ferrous metals including aluminum using two-color ratio technique.
3R 3R Fiber Optic	1300 - 6500°F or 700 - 3500°C 1300 - 6500°F or 700 - 3500°C	0.7 - 1.08 and 1.08μ 0.7 - 1.08 and 1.08μ	For difficult high temperature processes such as molten metal, wire rod, vacuum furnaces and kilns using two-color ratio technique.
3V 3V Fiber Optic	400 - 1200°C 500 - 1500°C	0.91 - 0.97μ 0.91 - 0.97μ	Specifically designed for gallium arsenide wafer temperature in MBE, MOCVD and MOMBE applications.

Modline 3 Catalog

Sensors

The Modline 3 system offers you the widest choice of non-contact infrared sensors to match any process. Modline 3 sensors offer sophisticated single lens reflex (SLR) focusing, that can view spots as small as 0.012 inches (0.3 mm); or for difficult, high temperature and harsh environments, some model series incorporate fiber optics for added flexibility.

The optical system, detector and electronics are housed in a rugged sealed casting rated NEMA 4 (IP66) to perform in the harsh industrial environments. Modline 3 sensors are designed to match existing mounting configurations and offer a choice of cooling and environmental protection accessories.

200 Series

Measures temperatures ranging from 900 to 4800°F (500 to 2600°C) and is intended for high temperature incandescent applications. It operates in a narrow spectral region from 0.7 to 1.0µm, utilizing an extremely stable silicon detector.

340 Series

Measures temperatures ranging from 75 to 1500°F (25 to 800°C) and is ideal for clear films of C-H type plastics or paints, waxes and oils. It operates in a very narrow wavelength band centered at 3.43µm.

600 Series

Measures temperatures ranging from 150 to 1400°F (80 to 800°C) and operates at 2.0 to 2.6µm. It's ideal for general purpose medium temperature applications such as thick plastics, rubber, textiles and metals.

700 Series

Measures temperatures ranging from 100 to 2500°F (50 to 2500°C) and operates at 4.8 to 5.3µm. It is ideal for glass surface temperatures in forming, bending, tempering, annealing and sealing.

800 Series

Measures temperatures ranging from 75 to 800°F (25 to 400°C) and operates at 7.92µm. This series measures thin film of all polyester (PET) and fluorocarbon plastics including thin glass and ceramics.

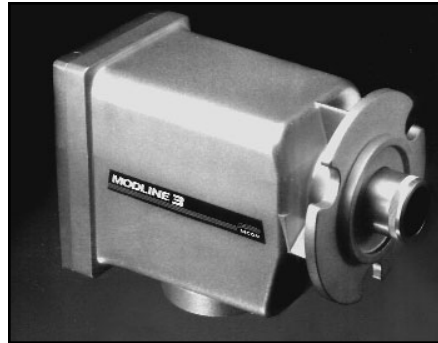

Series 340, 700, 800, 3R & 3L with SLR focusing

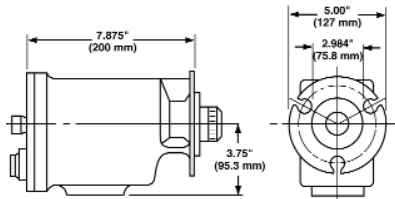

Series 200, 600, 3V and 3G with SLR focusing

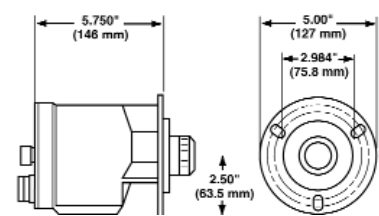

3G Series

Medium temperature thermometer measures temperatures ranging from 500 to 2500°F (250 to 1400°C) and operates at 1.5 to 1.6µm. It utilizes an InGaAs detector for exceptional stability, wider temperature spans and ability to operate at higher ambient temperatures. This series is ideal for medium temperature applications such as ferrous and non-ferrous metals.

3L Series

Low temperature two-color thermometer measures temperatures ranging from 500 to 1800°F (250 to 1000°C) and operates at 1.55 and 1.68µm lower ranges and 1.10 and 1.68µm upper ranges. It measures temperatures from the ratio of radiation signals of two adjacent wavelengths and not from absolute intensity. It will tolerate a more than 95% reduction in radiant intensity with virtually no error. This series is most appropriate for low temperature non-ferrous metal applications including aluminum. It features two Indium Gallium Arsenide (InGaAs) detectors which measure target signals simultaneously delivering highly stable, highly accurate and fast measurements.

3R Series

High temperature two-color thermometer measures temperatures ranging from 1300 to 6500°F (700 to 3500°C) and operates at 0.7 to 1.08 µm and 1.08 µm.

The series also uses Ircon's two-color technique to measure difficult high temperature applications. It is ideal for processes such as molten metal, wire and rod, vacuum furnaces and kilns.

3V Series

Gallium Arsenide thermometer measures temperatures ranging from 400 to 1200°C and operates in a narrow spectral region from 0.91 to 0.97µm. This series is specifically tailored for measuring gallium arsenide (GaAs) wafer temperatures.

Fiber Optic Sensor Option

Our fiber optic sensors are the ultimate in non-contact temperature measurement for difficult-to-read or obstructed targets. The following series are available as a fiber optic version:

Series and Temperature Range

200	200 to 4800°F (650 to 2600°C)
3G	650 to 2500°F (350 to 1400°C)
3R	1300 to 6500°F (700 to 3500°C)
3V	500 to 1500°C



Modline 3 Catalog

Standard Features

The Modline 3 Indicator/Processor is a micro computer based signal processor designed to operate with all Modline 3 sensors, an internal menu allows the user to indicate the sensor connected and the micro-computer provides the functions for that specific sensor. No calibration is necessary when changing sensors.

Analog Outputs

Four selectable isolated and linear outputs are available; 4-20 mA, 0-20 mA, 5 μ A per degree, and 0 to 10 Vdc. The outputs are adjustable to cover any portion of the instruments available temperature span to a minimum of 10 degrees.

Digital Interface

RS-485 digital communication interface communicates in half duplex to the computer. Command signals are used to make temperature request, setting adjustments, system status, system configuration, on/off control functions, service functions and PID control functions.

Auxiliary input

A remote 4-20 mA input can be field-selected to set the emissivity, the E-Slope or controller setpoint.

Smart Peak Picker

The Pick Picker circuitry responds to the highest instantaneous value of temperature and holds this value even if the temperature source is interrupted by smoke, steam, dust or intermittent targets. A rate of decay adjustment allows the instrument to follow the true target temperature but not be affected by the conditions previously mentioned.

The Modline 3 Peak Picker is a smart peak picker. When viewing products that have a hot leading edge like a piece of glass, the peaking function can be delayed for as long as 10 seconds to avoid this peak temperature. In addition, it can be reset manually or a reset setpoint can be selected. Should the temperature decay below this point, the Peak Picker will automatically reset. This setpoint is adjustable anywhere within the range of the instrument.

Track and Hold

Many processes may require that a control output be held even if the hot target is not in sight. For example, when a billet exits an induction coil, a temperature is obtained - if no billet is present, the controller would call for heat because it senses a cool target.

With a track and hold feature, the instrument receives a contact closure and holds the last seen temperature of the billet. All functions are held (the indicator, linear outputs and controller outputs) until the contact is opened.

Optional Features

On/Off Control

The On/Off controller provides two independent setpoints for alarms or control. Each setpoint is adjustable over the entire span of the instrument. Setpoint 1 can be externally set via the 4-20 mA linear input.

PID Control

The Modline 3 PID Controller provides a fully automated proportional controller for controlling heaters, lamps or speed controls. The controller can be operated in a manual mode using front panel controls or a remote setpoint via a 4-20 mA input. The PID control features Auto-tune, Bumpless Transfer and two Deviation Alarms which can be independently set either side of the operating setpoint.

Modline 3 Functions

All functions, either standard or optional, are easily set using the four controls on the front panel. Easily understood menus help you to make quick selections for fast start up and operation.

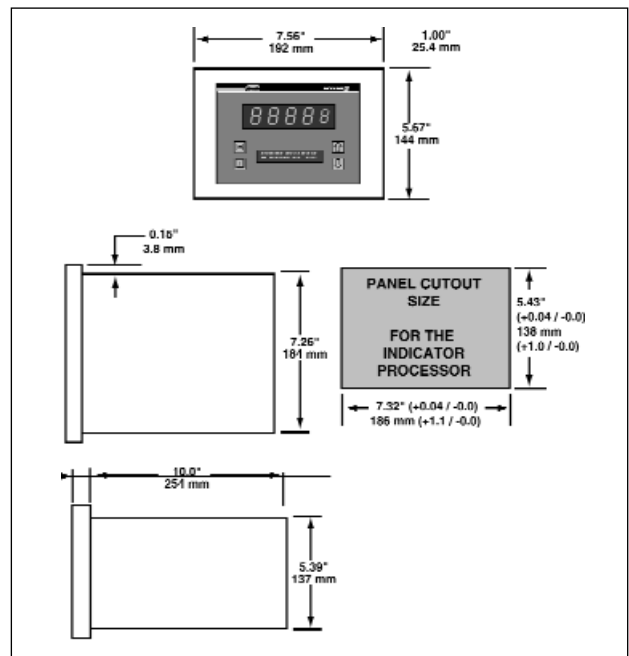

Typical Dimension Drawing shows panel mounting for Modline 3 Indicator/Processor

Modline 3

Operation Features

Front Panel Displays and Controls

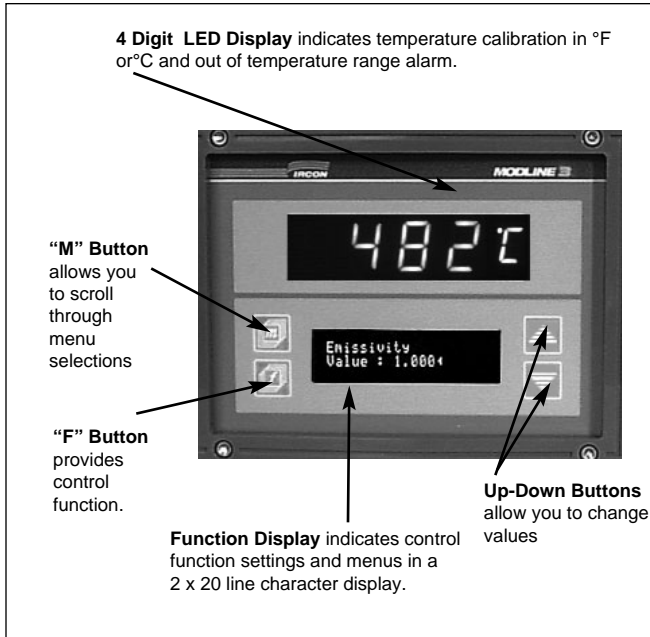

Rear Panel Connections

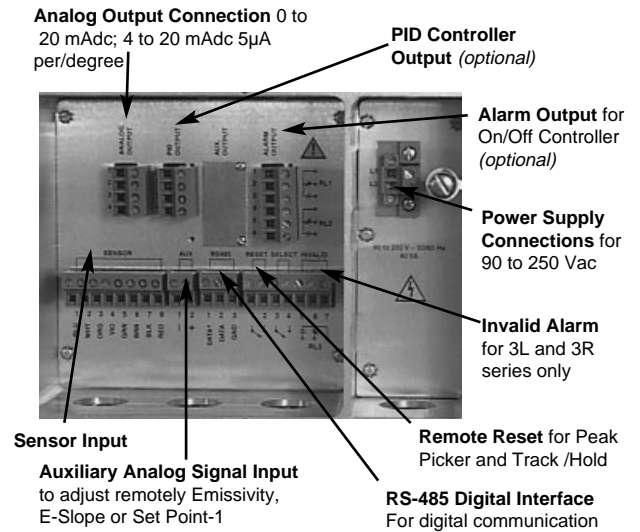

Control Function Display (In English, French or German)

Menus and functions are easily selected and displayed using two buttons, variable values are changed using up and down buttons.

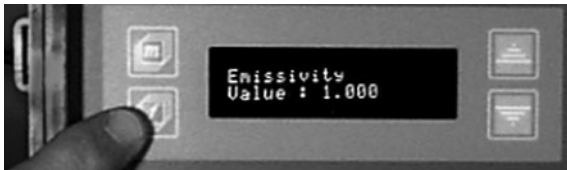

Select Emissivity and Value 0.100 to 1.000



Change Value using up/down buttons

Other Standard Function Selections

- E-Slope: 0.850 to 1.150
- Response Time: 0.01 to 60 sec.
- Peak Picker: On/Off, Decay Rate, Reset, Remote Reset, Auto Reset, Reset Below, Delay
- Track and Hold: On/Off
- Security Access: Panel Locked/Closed/Open
- Calibration: Cycle Cal.
- System Configuration Model Series: Text Language (English, French, German, Japanese)

Optional Accessories

Iron provides a variety of optional accessories for the Modline 3 System for the SLR sensors or the Fiber Optic Version to simplify mounting and to protect the sensors from hostile environments.

SLR Sensors

- Model AA-3 Air Purge
- Models SB-1 Swivel Mounting Base
- Model WA-3 Water Cooling Accessory
- Model WJ-5 Water Cooling Jacket
- All other Flange Mount Accessories and Sight Tubes.



Fiber Optic Sensors

- Model AA-5 Air Purge
- Model AP-5 Adapter Plate
- Model MB-5 Angle Mounting Bracket
- Model SB-5 Swivel Mounting Base with MC-5 Mounting Clamp

Modline 3 Catalog

System Specifications

CE Directives:

Meets EMC Directive 89/336/EEC for EMI/RFI and Safety Compliance tested to:
 EN 50081-2: Generic Emissions Standard
 EN 50082-2: Generic Immunity Standard
 EN 61010-1: Safety Standard

Spectral Response

Each series is designed to operate in a discrete wavelength band (see *Model Selection Chart*.)

Calibration / Accuracy

Accuracy @25°C:
 200, 3G, 3R, 3V series within 0.6% of reading (+ 1 digit) or 5°F (3°C), whichever is greater.

340, 600, 700, 800 and 3L series within 0.6% F.S. (+ 1 digit) or 5°F (3°C) whichever is greater.

Repeatability @25°C

Within 0.1% of full-scale temperature (+1 digit)

Response Time at Analog Output

Adjustable from 0.01 to 60 seconds

NEMA 4 (IP66 rated)

Sensor Housing and Indicator/processor enclosure

Operating Ambient

(without ambient cooling)

Series 200 and 3 G:

32 to 150°F (0 to 60°C)

Series 3L and 3R:

32 to 130°F (0 to 55°C)

Series 3V: 50 to 113°F (10 to 45°C)

Series 340, 600, 700, and 800:

50 to 130°F

Sensor Cable Silicone Rubber:

400°F (200°C) Max. Temp.

Indicator / Processor:

32 to 122°F (0 to 50°C)

Humidity

10 to 90% non-condensing

Enclosure

allows mounting two Indicator/Processors side-by-side in 19 inch rack; Size: 7.56 x 5.67" (192 x 144 mm)

Selectable Analog Outputs

are isolated from ground

Select. Analog Outputs (cont'd)

0 to 20 mAdc with a 1000 Ω max.

4 to 20 mAdc with a 1000 Ω max

5 μAdc / degree F or C, (1mV/°

0 to 10 Vdc

[max 4000 mV] across 200 Ω

resistor, typical deviation two degrees from display)

Digital Communication

RS-485 Digital Interface

Emissivity Range*

0.100 to 1.000.

*see pages 7 & 8 for limitations.

E Slope Range*

0.850 to 1.150.

*see pages 7 & 8 for limitations.

Power Requirements

90 to 250 Vac, 50/60 Hz, 40VA max.

Weight

Sensor: 7 to 8 lbs (3.2 to 3.6 kg)

Indicator/Processor:

9 lbs (4 kg) - approximate weight

Unique to Sensor Series 3L & 3R Two-Color (Ratio) Thermometer

3L Spectral Response

Adjacent bands: 1.50 to 1.60μ and 1.65 to 1.71μ or 1.00 to 1.20μ and 1.65 to 1.71μ.

3R Spectral Response

Adjacent bands: 0.7 to 1.08μ and a narrow band centered at 1.08μ.

Signal Reduction Range

Caused by low emissivity, non-resolved or obliterated target above 575°F (300°C) for 3L series and above 1500°F (800°C) for 3R Series. Will tolerate about 95% reduction in radiation intensity.

Invalid Alarm

Form C relay outputs rated at 24 VAC/DC; @ 1 Amp. Resistive or Inductive.

Peak Picker

Rise Time

Same as selected Response Time (0.01 to 60 seconds).

Adjustable Decay Rate

0.00 to 300°F (0.00 to 300°C) per second, depending on the instrument model.

Peak Picker Reset

Internal Reset
 two Modes: Manual and Auto
 External Reset via contact closure.

On/Off Controller/Alarm with Relay Outputs

Response Time

Same as selected Response Time (0.01 to 60 seconds).

Internal Set Point

Adjustable over full temperature span of the instrument model.

Remote Set Point 1

Input Signal of 4 to 20 mA, daisy chain compatible.

Relay Outputs

Two Form C relay outputs rated at 24 V AC/DC; @ 1 Amp. Resistive or Inductive.

Relay Delay Time

1 to 2 milliseconds

Hysteresis

2°F (2°C)

PID Controller with Auto Tune and Deviation Alarms

Pid Output

4 to 20 mAdc isolated. 1000 Ohm maximum.

Remote Set Point

Input Signal 4 to 20 mA, daisy chain compatible.

Internal Set Point

Adjustable over full temperature span of the instrument model.

Proportional Band (P)

0.1 to 200.0%

Reset Rate

(I) - 0.01 to 99.00 repeats per minute with an Off position.

Rate Time

(D) - 0.001 to 9.900 minutes, with Off position.

Load Demand

0 to 100% of output

Manual Adjust

0.0 to 100.0% of output

Deviation Alarm Set Points

Adjustable for HI and LO set points over full temperature span of instrument model, each with Off position.

Deviation Alarm Output

Relay Outputs for HI and LO Alarms. Use two Form C relay outputs rated at 24 V AC/DC; @ 1Amp. Resistive or Inductive.

Modline 3 Catalog

Model Identification Chart



Model Number Explanation Example: 33-05F05-0-0-0-0

BLOCK A 3 3 = Modline 3 Series 340

BLOCK B 0 5 F 0 5 = 150 to 500°F Temperature Range
D/50 Resolution

BLOCK C 0 = Signal Conditioning
Peak Picker and Track and Hold

BLOCK D 0 = Analog Signal Output - 4 to 20mA,
0 to 20mA, and 5mA per degree

BLOCK E 0 = Digital Communication
RS-485 Digital Interface

BLOCK F 0 = No Controller Output

BLOCK A - Series Designation

32 = 200 Series
33 = 340 Series
36 = 600 Series
37 = 700 Series
38 = 800 Series
3G = 3G Series
3L = 3L Series
3R = 3R Series
3V = 3V Series

BLOCK B - Temperature Range, Optical Characteristics and Fiber Optic Options (Check One)

Note: Some sensor models are marked with response time restrictions. All other models have an adjustable range of 0.01 to 60 seconds.

200 Series* – 0.7 to 1.0 μ

20F05 = 900 – 2000°F D/50
24F10 = 1000 – 2400°F D/100
30F20 = 1200 – 3000°F D/200
48F30 = 1400 – 4800°F D/300

11C05 = 500 – 1100°C D/50
13C10 = 550 – 1300°C D/100
14C10 = 600 – 1400°C D/100
15C20 = 650 – 1500°C D/200
16C30 = 800 – 1600°C D/300
26C30 = 750 – 2600°C D/300

* Emissivity span is restricted to 0.3 to 1.0 for the first 100°F (55°C) for all temperature ranges.

200 Series Fiber Optic Options**

10 ft (3 m) fiber optic cable
25FF5 = 1200 – 2500°F D/30
25FF8 = 1200 – 2500°F Extension Tip
30FF6 = 1300 – 3000°F D/60
30FF7 = 1300 – 3000°F D/30 x D/150
30FF8 = 1300 – 3000°F Extension Tip
48FF6 = 1800 – 4800°F D/60
48FF7 = 1800 – 4800°F D/30 x D/150
48FF8 = 1800 – 4800°F Extension Tip

BLOCK B (cont.)

200 Series Fiber Optic Options (cont.) 10 ft (3 m) fiber optic cable

15CF5 = 650 – 1500°C D/30
15CF8 = 650 – 1500°C Extension Tip
20CF6 = 700 – 2000°C D/60
20CF7 = 700 – 2000°C D/30 x D/150
20CF8 = 700 – 2000°C Extension Tip
26CF6 = 750 – 2600°C D/60
26CF7 = 750 – 2600°C D/30 x D/150
26CF8 = 750 – 2600°C Extension Tip

** Emissivity span is restricted to 0.2 to 1.0 for the first 100°F (55°C) for all temperature ranges.

340 Series – 3.43 μ (0.14μ Band)

04F05 = 75 – 400°F D/50*
05F05 = 150 – 500°F D/50**
06F05 = 200 – 600°F D/50
10F10 = 300 – 1000°F D/100
15F10 = 500 – 1500°F D/100

02C05 = 25 – 200°C D/50*
03C05 = 75 – 300°C D/50**
04C05 = 100 – 400°C D/50
05C10 = 150 – 500°C D/100
08C10 = 200 – 800°C D/100

* Limited range of response time adjustment is 2.00 to 60 seconds.

** Limited range of response time adjustment is 0.10 to 60 seconds.

600 Series SLR Version – 2.0 to 2.6μ

04F15 = 150 – 400°F D/150*
05F15 = 200 – 500°F D/150*
06F15 = 250 – 600°F D/150
08F15 = 350 – 800°F D/150
10F15 = 500 – 1000°F D/150
14F15 = 600 – 1400°F D/150

BLOCK B (cont.)

600 Series SLR Version (cont'd)

02C15 = 80 – 200°C D/150*
03C15 = 120 – 300°C D/150*
04C15 = 160 – 400°C D/150
06C15 = 250 – 600°C D/150
08C15 = 350 – 800°C D/150

* Limited range of response time adjustment is 0.10 to 60 seconds.

700 Series – 4.8 to 5.3μ

06F05 = 100 – 600°F D/50*
10F05 = 200 – 1000°F D/50**
15F10 = 500 – 1500°F D/100
25F10 = 500 – 2500°F D/100

03C05 = 50 – 300°C D/50*
06C05 = 100 – 600°C D/50**
08C10 = 300 – 800°C D/100
13C10 = 300 – 1300°C D/100
25C10 = 1000 – 2500°C D/100

* Limited range of response time adjustment is 1.0 to 60 seconds.

** Limited range of response time adjustment is 0.10 to 60 seconds.

800 Series* – 7.92μ (0.3μ Band)

08F02 = 75 – 800°F D/20

04C02 = 25 – 400°C D/20

* Limited range of response time adjustment is 0.25 to 60 seconds.

Note: Model Selection Chart continued on following page.

Modline 3 Catalog

Model Selection Chart (continued)

BLOCK B (cont.)

3G Series SLR Version* – 1.5 to 1.6 μ

18F05 = 500 – 1800°F D/50
10F10 = 600 – 2000°F D/100
25F15 = 700 – 2500°F D/150

10C05 = 250 – 1000°C D/50
11C10 = 350 – 1100°C D/100
14C15 = 400 – 1400°C D/150

* Emissivity span is restricted to 0.3 to 1.0 for the first 100°F (55°C) for all temperature ranges.

3G Series Fiber Optic Options*

10 ft (3 m) fiber optic cable

22FF5 = 650 – 2200°F D/30
22FF8 = 650 – 2200°F Extension Tip
25FF6 = 800 – 2500°F D/60
25FF7 = 800 – 2500°F D/30 x D/150
25FF8 = 800 – 2500°F Extension Tip

12CF5 = 350 – 1200°C D/30
12CF8 = 350 – 1200°C Extension Tip
14CF6 = 450 – 1400°C D/60
14CF7 = 450 – 1400°C D/30 x D/150
14CF8 = 450 – 1400°C Extension Tip

* Emissivity span is restricted to 0.3 to 1.0 for the first 100°F (55°C) for all temperature ranges.

3L Series** – 1.5 to 1.6 μ and 1.65 to 1.71 μ

10F05 = 500 – 1000 F D/50
14F10 = 700 – 1400 F D/100
18F10 = 1000 – 1800 F D/100*

05C05 = 250 – 550°C D/50
07C10 = 400 – 750°C D/100
10C10 = 550 – 1000°C D/100*

* Indicates spectral response of 1.00 to 1.20 μ and 1.65 to 1.71 μ .

** Response time of 0.02 to 60 seconds for all models.

Note: Specifications subject to change without notice.

BLOCK B (cont.)

3R Series SLR Version – 0.7 to 1.08 μ and 1.08 μ

25F05 = 1300 – 2500°F D/50
32F05 = 1800 – 3200°F D/50
40F10 = 2000 – 4000°F D/100
65F15 = 2500 – 6500°F D/150

14C05 = 700 – 1400°C D/50
16C05 = 900 – 1600°C D/50
20C10 = 1100 – 2000°C D/100
24C05 = 900 – 2400°C D/50
35C15 = 1500 – 3500°C D/150

3R Series Fiber Optic Version

10 ft (3 m) fiber optic cable

25FF5 = 1300 – 2500°F D/30
25FF8 = 1300 – 2500°F Extension Tip
32FF5 = 1800 – 3200°F D/30
32FF8 = 1800 – 3200°F Extension Tip
40FF5 = 2000 – 4000°F D/30
40FF8 = 2000 – 4000°F Extension Tip
65FF6 = 2500 – 6500°F D/60
65FF7 = 2500 – 6500°F D/30 x D/150

14CF5 = 700 – 1400°C D/30
14CF8 = 700 – 1400°C Extension Tip
16CF5 = 900 – 1600°C D/30
16CF8 = 900 – 1600°C Extension Tip
20CF5 = 1100 – 2000°C D/30
20CF8 = 1100 – 2000°C Extension Tip
24CF6 = 900 – 2400°C D/60
24CF7 = 900 – 2400°C D/30 x D/150
35CF6 = 1500 – 3500°C D/60
35CF7 = 1500 – 3500°C D/30 x D/150

3V Series SLR Version* – 0.91 to 0.97 μ

10C02 = 400 – 1000°C D/20
12C05 = 450 – 1200°C D/50

* Adjustable range of response time 0.10 to 60 seconds

BLOCK B (cont.)

3V Series Fiber Optic Version

10 ft (3 m) fiber optic cable

15CF5 = 500 – 1500°C D/30 †
15CF8 = 500 – 1500°C Extension Tip †

† These models are restricted to sensing head ambient temperatures of 50 to 113°F (10 to 45°C) and a minimum emissivity setting of 0.400.

BLOCK C Signal Conditioning

0 = Peak Picker and Track & Hold

BLOCK D Analog Signal Output

0 = 4 to 20mA, 0 to 20mA, or 5 μ A per Degree
1 = 0 to 10 Vdc

BLOCK E Digital Communication

0 = RS 485 Digital Interface

BLOCK F Controller Outputs

0 = None
1 = PID Controller with deviation alarms and 4 to 20mA isolated output
2 = 2-Point On/Off Controller with relay outputs



ISO 9001 : 2000
Quality System
Certified

NIST Calibration Provider



World Headquarters

7300 North Natchez Ave. • Niles, IL 60714 USA
Phone: 847 967 5151 ir 800 323 7660 • Fax: 847 647 0948
Web site: www.ircon.com • E-mail: info@ircon.com

European Headquarters

Databankweg 6c • 3821 AL • Amersfoort, The Netherlands
Phone: 31 33 450 4321 • Fax: 31 33 450 4320
E-mail: info@ircon.nl