

PRODUCT FAX SHEET

IRCON, INC.
Phone (847) 967-5151
Toll Free (800) 323-7660
Fax (847) 647-0948
Web site: www.ircon.com



Temp View Mini LP Loop Powered Process Indicator Temp View Mini CL Current Loop Indicator



- DUAL RANGE, 4 to 20 mA OR 10 to 50 mA
- 3½-DIGIT, 0.6" (15.2 mm) HIGH DIGITS

- POSITIVE IMAGE TRANSFLECTIVE LCD WITH RED BACKLIGHT OR POSITIVE IMAGE REFLECTIVE LCD (Temp View Mini LP)
- POSITIVE IMAGE TRANSFLECTIVE LCD WITH RED BACKLIGHT OR NEGATIVE IMAGE TRANSMISSIVE WITH RED OR YELLOW/GREEN BACKLIGHT (Temp View Mini CL)
- SPAN AND OFFSET CAPABILITY
- NEGATIVE AND OVERRANGE INDICATION
- SELECTABLE DECIMAL POINT POSITION
- NEMA 4X/IP65 SEALED FRONT PANEL BEZEL
- FITS DIN STANDARD CUT-OUT 2.68" (68 mm) X 1.30" (33 mm)



FOR USE IN HAZARDOUS LOCATIONS:
Class I, Division 2, Groups A, B, C, and D
Class II, Division 2, Groups F and G
Class III, Division 2

DESCRIPTION

The **Temp View Mini LP** and **CL** are additions to the **Temp View** product line. The **Temp View Mini LP** uses a 4 to 20 mA or a 10 to 50 mA input signal as operating power. The input signal is also used to power the backlighting on the unit. The **Temp View Mini CL** uses a 4 to 20 mA or a 10 to 50 mA input signal to power the unit. An external power supply is used to power the backlighting to provide a brighter, more consistent display and a lower compliance voltage.

The units have a 3½-digit LCD display with 0.6" (15.2 mm) high digits and a DIP switch selectable decimal point. The **Temp View Mini LP** display is available in positive image reflective (dark digits, reflective background) or positive image transfective (dark digits, illuminated background) with red backlighting. The **Temp View Mini CL** display is available in positive image transfective (dark digits, illuminated background) with red or yellow/green backlighting or negative image transmissive (illuminated digits, dark background) with red or yellow/green backlighting.

The ability to scale the display allows indication in any desired unit of measurement such as temperature, pressure, humidity, fluid flow, etc. The unit is calibrated at the factory with 0.0 displayed @ 4 mA input and 100.0 displayed @ 20 mA input.

The units are contained in a lightweight, high impact plastic case with a clear viewing window. When properly installed, the sealed front panel meets NEMA 4X/IP65 specifications for wash-down and dusty environments.



CAUTION: Read complete instructions prior to installation and operation of the unit.

SAFETY SUMMARY

All safety related regulations, local codes and instructions that appear in the manual or on equipment must be observed to ensure personal safety and to prevent damage to either the instrument or equipment connected to it. If equipment is used in a manner not specified by the manufacturer, the protection provided by the equipment may be impaired.



WARNING - EXPLOSION HAZARD - SUBSTITUTION OF COMPONENTS MAY IMPAIR SUITABILITY FOR CLASS I, DIVISION 2 / CLASS II, DIVISION 2 / CLASS III, DIVISION 2

SPECIFICATIONS

1. **DISPLAY:** 3½-digit (-1999 to 1999), 0.6" (15.2 mm) high digits.
The **Temp View Mini LP** is available with a positive image reflective LCD or a red backlit positive image transfective LCD. The intensity of the backlighting will vary with the input signal.
The **Temp View Mini CL** is available with a positive image transfective LCD with red or yellow/green backlighting or a negative image transmissive with red or yellow/green backlight.
A minus sign is displayed when the indicator is adjusted for a negative offset.
Ovrange: Ovrange is indicated by a "1" in the most significant digit and the blanking of the three least significant digits.
2. **EXTERNAL BACKLIGHT POWER:** (**Temp View Mini CL** only)
9 - 28 VDC, @35 mA typ., 50 mA max. Must use the MLPS or a Class 2 (NEC) or SELV rated power supply. Above 26 VDC, derate the operating temperature to 50°C.

Dimensions "in inches (mm)"

Note: Recommended minimum clearance (behind the panel) for mounting clip installation is 2.15" (54.6) H x 3.00" (76.2) W.

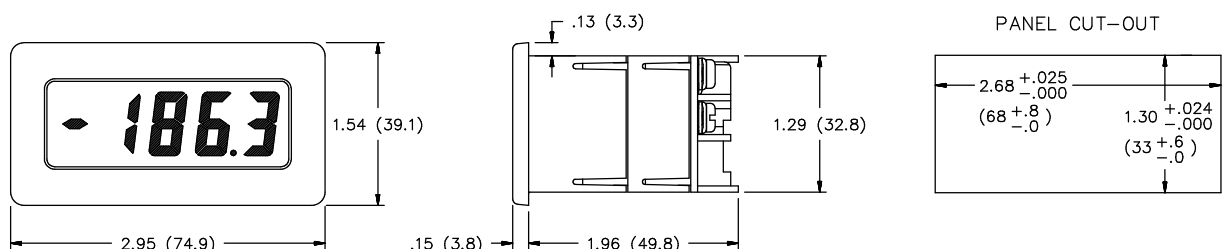

SPECIFICATIONS (Cont'd)

3. **DECIMAL POINTS:** Three DIP switch selectable, decimal point positions allow the display to be read in tenths, hundredths or thousandths.
4. **MAXIMUM VOLTAGE DROP:**
3.2 VDC for Temp View Mini LP00
4.0 VDC for Temp View Mini LP40
3.2 VDC for Temp View Mini CL all models
5. **EQUIVALENT RESISTANCE:**
Temp View Mini LP00: 800 Wmax. @ 4 mA; 160 Wmax. @ 20 mA
320 Wmax. @ 10 mA; 65 Wmax. @ 50 mA
Temp View Mini LP40: 1000 Wmax. @ 4 mA; 200 Wmax. @ 20 mA
400 Wmax. @ 10 mA; 80 Wmax. @ 50 mA
Temp View Mini CL (all models): 800 Wmax. @ 4 mA; 160 Wmax. @ 20 mA
320 Wmax. @ 10 mA; 65 Wmax. @ 50 mA
6. **MAXIMUM ALLOWABLE INPUT CURRENT:** 100 mA
7. **SCALING RANGE:**
Span: Two potentiometers provide a coarse and fine span adjustment. Span range = 0 to 2000.
Offset: Two potentiometers provide a coarse and fine zero offset adjustment. Offset range = -1999 to 1999.
8. **LINEARITY:** (@ 23°C, Less than 85% RH) $\pm(0.1\% + 1 \text{ digit})$.
9. **READING RATE:** 2.5 per second, nominal.
10. **RESPONSE TIME:** 1.5 seconds to settle for a step change.
11. **NORMAL MODE REJECTION:** 60 dB 50/60 Hz
12. **TEMPERATURE EFFECTS:**
Span Temperature Coefficient: 100 PPM/°C
Offset Temperature Coefficient: 0.2 digits/°C
13. **CONSTRUCTION:** High impact plastic case with clear viewing window. (Panel gasket and mounting clips included.) This unit is rated for NEMA 4X/IP65 indoor use. Installation Category II, Pollution Degree 2
14. **CERTIFICATIONS AND COMPLIANCES:**
UL: LISTED by Und. Lab. Inc. to U.S. and Canadian safety standards

EMC EMISSIONS:

Meets EN 50081-1: Residential, Commercial, and Light Industry
CISPR 11 Radiated and conducted emissions

EMC IMMUNITY:

Meets EN 50082: Industrial Environment.
ENV 50140 - Radio-frequency radiated electromagnetic field ¹
ENV 50141 - Radio-frequency conducted electromagnetic field ²
EN 61000-4-2 - Electrostatic discharge (ESD)
EN 61000-4-4 - Electrical fast transient/burst (EFT)
EN 61000-4-8 - Power frequency magnetic field

Note:

1. *No loss of performance during EMI disturbance at 1.5 V/m. For operation without loss of performance at 10 V/m: Unit is panel mounted in a metal enclosure (Buckeye SM7013-0 or equivalent) which provides at least 16 dB shielding effectiveness. Metal panel is connected to earth ground.*
2. *No loss of performance during EMI disturbance at 6 Vrms. Permissible loss of performance during EMI disturbance at 10 Vrms: Process signal deviation less than 1% of full scale. For operation without loss of performance: Install power line filter, RLC #LFIL0000 or equivalent. Install 1 ferrite core, RLC #FCOR0000 or equivalent, to signal cable at unit.*

Refer to the EMC Installation Guidelines of this bulletin for additional information.

15. ENVIRONMENTAL CONDITIONS:

Operating Temperature: 0° to 60°C

(Derate backlight voltage to 26 VDC above 50°C.)

Storage Temperature: -40° to 80°C

Operating and Storage Humidity: 85% max. (non-condensing) from 0°C to 60°C.

Altitude: Up to 2000 meters

16. **WEIGHT:** 3.3 oz. (93.5 g)

INSTALLATION

When properly installed, the **Temp View Mini** meets NEMA 4X/IP65 requirements for indoor use. The units are intended to be mounted into an enclosed panel. A sponge rubber gasket, mounting clip, two screws, and nut fasteners are provided to install and seal the unit in the panel cutout.

Installation Environment

The unit should be installed in a location that does not exceed the maximum operating temperature and provides good air circulation. Placing the unit near devices that generate excessive heat should be avoided.

The bezel should be cleaned only with a soft cloth and neutral soap product. Do NOT use solvents.

Continuous exposure to direct sunlight may accelerate the aging process of the bezel.

The following procedure assures proper installation:

1. Cut the panel opening to the specified dimensions. Remove burrs and clean the panel opening.
2. Slide nut fastener into slot on mounting clip and then insert mounting screw through nut on both sides of mounting clip. The tip of mounting screw should not project through hole on clip.
3. Slide the panel gasket over the rear of the unit to the back of the bezel. Install **Temp View Mini** unit through panel cutout.
4. Slide mounting clip over rear of unit until the clip is against back of panel. The mounting clip and **Temp View Mini** housing has a latching feature to hold the unit in place until tightened.

Note: Hold the Temp View Mini front bezel in place when sliding the mounting clip into position.

5. Alternately tighten each mounting screw to ensure uniform gasket pressure. Visually inspect the gasket for proper seal. The gasket should be

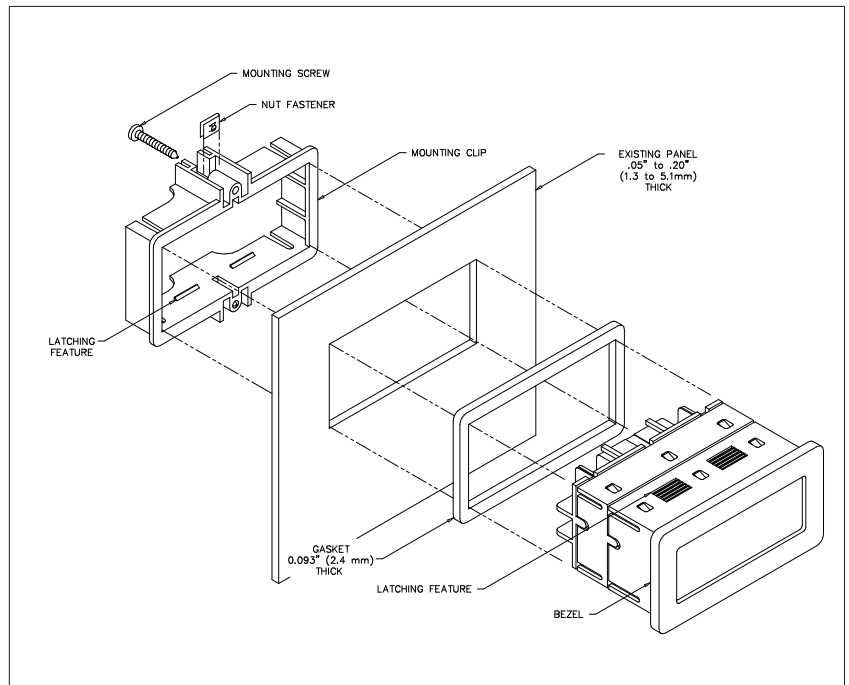

compressed to approximately 75 to 80% of its original thickness. (Recommended torque is 28 to 36 in.-oz.)

6. If the gasket is not adequately compressed and the mounting screws cannot be tightened any further, loosen the mounting screws and insure that the clip is latched as closely as possible to the panel.
7. Repeat Step #6 for tightening the mounting screws.

EMC INSTALLATION GUIDELINES

Although this unit is designed with a high degree of immunity to ElectroMagnetic Interference (EMI), proper installation and wiring methods must be followed to ensure compatibility in each application. The type of the electrical noise, source or coupling method into the unit may be different for various installations. Cable length, routing and shield termination are very important and can mean the difference between a successful installation or a troublesome installation. Listed below are some EMC guidelines for successful installation in an industrial environment.

- Use shielded (screened) cables for all Signal and Control inputs. The shield (screen) pigtail connection should be made as short as possible. The connection point for the shield depends somewhat upon the application. Listed below are the recommended methods of connecting the shield, in order of their effectiveness.
 - Connect the shield only at the panel where the unit is mounted to earth ground (protective earth).
 - Connect the shield to earth ground at both ends of the cable, usually when the noise source frequency is above 1 MHz.
 - Connect the shield to common of the unit and leave the other end of the shield unconnected and insulated from earth ground.
- Never run Signal or Control cables in the same conduit or raceway with AC power lines, conductors feeding motors, solenoids, SCR controls, and heaters, etc. The cables should be run in metal conduit that is properly grounded. This is especially useful in applications where cable runs are long and portable two-way radios are used in close proximity or if the installation is near a commercial radio transmitter.

- Signal or Control cables within an enclosure should be routed as far away as possible from contactors, control relays, transformers, and other noisy components.
- In extremely high EMI environments, the use of external EMI suppression devices, such as ferrite suppression cores, is effective. Install them on Signal and Control cables as close to the unit as possible. Loop the cable through the core several times or use multiple cores on each cable for additional protection. Install line filters on the power input cable to the unit to suppress power line interference. Install them near the power entry point of the enclosure. The following EMI suppression devices (or equivalent) are recommended:

Ferrite Suppression Cores for signal and control cables:

Fair-Rite # 0443167251 (RLC #FCOR0000)

TDK # ZCAT3035-1330A

Steward #28B2029-0A0

Line Filters for input power cables:

Schaffner # FN610-1/07 (RLC #LFIL0000)

Schaffner # FN670-1.8/07

Corcom #1VR3

Note: Reference manufacturer's instructions when installing a line filter.

- Long cable runs are more susceptible to EMI pickup than short cable runs. Therefore, keep cable runs as short as possible.

WIRING CONNECTIONS

All conductors should meet voltage and current ratings for each terminal. Also cabling should conform to appropriate standards of good installation, local codes and regulations. It is recommended that power supplied to the unit (AC or DC) be protected by a fuse or circuit breaker.

The electrical connections are made via screw-clamp terminals located on the back of the unit. When wiring the unit, use the label to identify the wire position with the proper function. Strip the wire, leaving approximately 1/4" of bare wire (stranded wires should be tinned with solder). Insert the wire into the screw-clamp terminal and tighten the screw until the wire is clamped tightly. Each terminal can accept up to two #14 AWG wires.

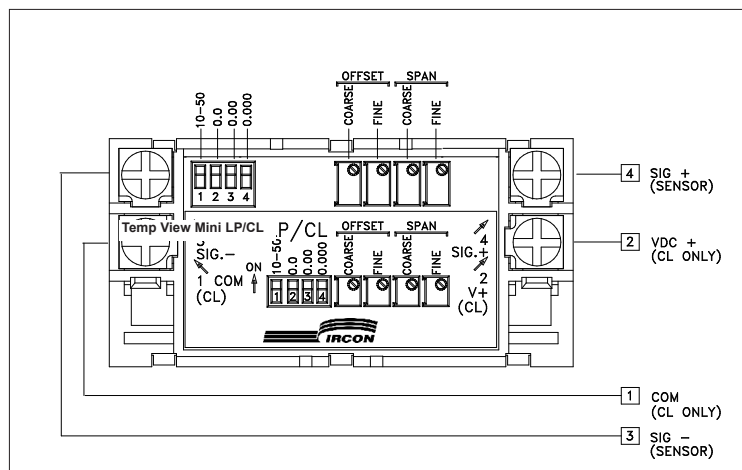

Temp View Mini LP/CL SIGNAL INPUT

The current range is selected by setting DIP switch S1 to the OFF position for a 4 to 20 mA input or ON for a 10 to 50 mA input. Attach the signal wires to terminals 3 (SIG-) and 4 (SIG+) observing the correct polarity. The (SIG-) signal input circuit is not reverse polarity protected.

Backlight Power (Temp View Mini CL only)

Attach a 9 to 28 VDC supply to terminals 1 (COM) and 2 (V+) to power the backlight. Terminals 3 (SIG-) and 1 (COM) are AC coupled with a capacitor. This limits the isolation between these terminals to 50 VDC maximum.

OFFSET ADJUSTMENTS

The minimum currents are not zero based with 4 to 20 mA and 10 to 50 mA signals. To obtain a zero minimum display reading, the display must be offset. The display on the **Temp View Mini** can be offset by adjusting the Coarse and Fine Offset pots.

SPAN ADJUSTMENTS

Span is defined as the numerical range that the display traverses, disregarding the decimal point, when the input signal is varied from minimum to maximum (4 to 20 mA or 10 to 50 mA). For example; if a unit is to display 250 @ 4 mA and 1000 @ 20 mA, the span is 750 (the difference between 250 and 1000). Had the minimum display been -250, the span would be 1250 (1000 - (-250) = 1250). The **Temp View Mini** can be set to operate over a wide span range by adjusting the Coarse and Fine Span adjustment pots. The Coarse Span pot is used to get the display to within a couple of counts of the desired reading, and the Fine Span pot is used to adjust for the exact reading.



WARNING - EXPLOSION HAZARD - DO NOT DISCONNECT EQUIPMENT UNLESS POWER HAS BEEN SWITCHED OFF OR THE AREA IS KNOWN TO BE NON-HAZARDOUS.

DECIMAL POINT POSITION SELECTION

The decimal point position is DIP switch selectable for one of three locations. The **Temp View Mini** can be set up to read in 10ths, 100ths, or 1000ths. If all the DIP switches are set to the "OFF" position, no decimal point will appear on the display. The DIP switches are located at the rear of the unit.

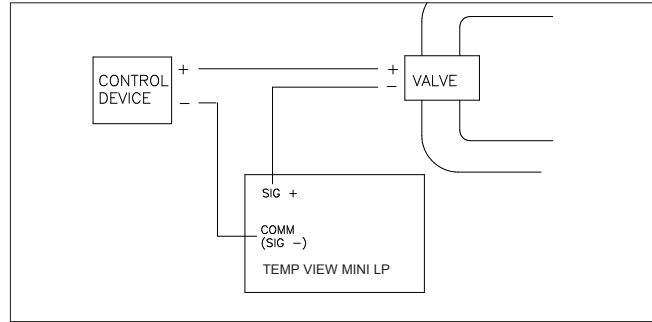

APPLICATION EXAMPLE

Operation of a refinery process required a local display of the position of a remote pipeline valve. The display would indicate 0 (zero) when the valve was fully closed with an input signal of 4 mA. When the valve was fully open the display would indicate 100 with an input signal of 20 mA.

Both the **Temp View Mini LP** and **CL** meet the necessary requirements.

CALIBRATING THE DISPLAY

Calibrating the **Temp View Mini** requires either an accurate adjustable constant current supply or the **Temp View Mini** can be installed and scaled with the process sensor connected to the **Temp View Mini**. To calibrate the unit, proceed as follows.

1. Set DIP switching for the desired current range.
2. Select the desired decimal point position.
3. Apply the minimum input signal to the **Temp View Mini** and adjust the COARSE OFFSET to display the approximate desired minimum value.
4. Apply the maximum input signal to the **Temp View Mini** and adjust the COARSE SPAN to display the approximate desired maximum value.
5. Repeat steps 3 and 4 until the minimum and maximum values are within the desired values.
6. Apply the minimum input signal to the **Temp View Mini** and adjust the FINE OFFSET to display the exact desired minimum value.
7. Apply the maximum input signal to the **Temp View Mini** and adjust the FINE SPAN to display the exact desired maximum value.
8. Apply the minimum input signal and verify that the display indicates correctly.
9. Apply the maximum input signal and verify that the display indicates correctly.
10. Repeat Steps 6 through 9 until display reads exact.

Note: The Temp View Mini LP/CL display is factory calibrated to indicate 0.0 to 100.0 with an input of 4 to 20 mA at approximately 25°C

BLOCK DIAGRAM

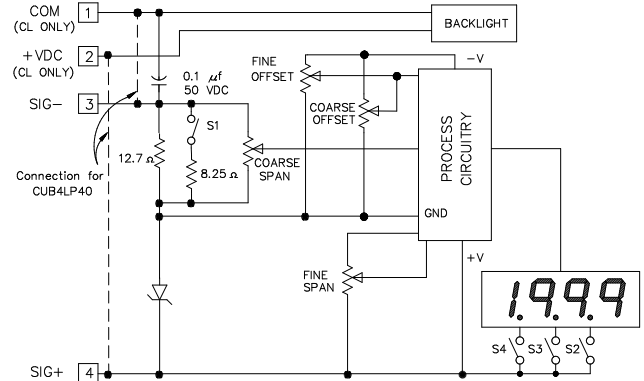

TROUBLESHOOTING

For further technical assistance, call Itron, Inc., Niles, Illinois at 847-967-5151 and ask for the Technical Services Department.